



Operation and Installation Manual for AU Series

M5-TL
M4-TL
M3-TL

AU



This manual is subject to change.
Please check our website at <http://www.delta-americas.com/SolarInverters.aspx>
for the most up-to-date manual version.

© Copyright – DELTA ELECTRONICS (SHANGHAI) CO.,LTD. - All rights reserved.

This manual accompanies our equipment for use by the end users. The technical instructions and illustrations contained in this manual are to be treated as confidential and no part may be reproduced without the prior written permission of DELTA ELECTRONICS (SHANGHAI) CO.,LTD. Service engineers and end users may not divulge the information contained herein or use this manual for purposes other than those strictly connected with correct use of the equipment. All information and specifications are subject to change without notice.

Table of Contents

1	General safety information	4
1.1	Safety and Advisory symbols	5
1.2	Safety Instructions	6
2	Introduction	7
2.1	System	8
2.2	Data evaluation and communication	8
2.3	Technical structure of the solar inverter	9
2.4	Ambient temperature	10
2.5	Solar inverter PV input DC voltage range	10
2.6	Efficiency	11
2.7	Equipment overview	11
2.8	Inverter type and safety labels	12
3	Installation	15
3.1	Visual inspection	17
3.2	Installation Information	17
3.3	Mounting the inverter	18
3.4	Electrical connection	20
3.5	Mounting the inverter	21
4	Electrical connections	22
4.1	General safety	22
4.2	AC vgrid connection	23
4.3	External DC switch	23
4.4	AC circuit breaker requirements	24
4.5	Grounding conductor	24
4.6	Lightning and surge protection	24
4.7	Multiple inverters	24
4.8	PV string considerations	24
4.9	Inverter connections	25
4.9.1	General information	25
4.9.2	PV array string input information	28
4.9.3	Inverter AC output wire connections	30
5	Commissioning the PV system	30
5.1	Status LEDs	31
5.2	LED Indication	31

5.2.1	Introduction	31
5.2.2	LED Message	31
5.3	Inverter turn-on procedure	32
5.4	Inverter turn-off procedure	
5.3	M Series APP(Android) Manual	32
5.3.1	Introduction	32
5.3.2	Installation	32
5.3.3	Connection	33
5.3.4	Menu Structure	33
5.3.5	Functions	35
6	Production information	43
7	Repair	44
8	Decommissioning, transport, storage, disposal	44
8.1	Decommissioning	45
8.2	Packaging	45
8.3	Transport	46
8.4	Storage	46
8.5	Dispose	46
9	Certificate and technical data	46
9.1	Certificate	46
9.2	Technical data	46
10	Warranty	51
11	Glossary	52

IMPORTANT SAFETY INSTRUCTIONS

SAVE THESE INSTRUCTIONS

1 General safety information

This manual contains important instructions for Delta's M series inverters that should be followed during installation and maintenance of the inverter. To reduce the risk of electrical shock, and to ensure the safe installation and operation of the Delta M series inverter, follow these instructions.





Delta models M3-TL, M4-TL and M5-TL inverters are designed and tested to meet all applicable AS/NZS and International safety standards. However, like all electrical and electronic equipment, safety precautions must be observed and followed during installation and operation of the Delta M series inverters to reduce the risk of personal injury and to ensure a safe installation.

Installation, commissioning, service, and maintenance of Delta models M3-TL, M4-TL and M5-TL inverters must only be performed by qualified personnel that are licensed and/or satisfy state and local jurisdiction regulations.

Before starting installation or commissioning of the Delta models M3-TL, M4-TL and M5-TL, read through the entire manual and note all DANGER! WARNING! CAUTION! and NOTICE! statements.

All AS electrical installations must comply and be in accordance with all the state, local, utility regulations, and all applicable standard.

1.1 Safety and Advisory symbols

DANGER	DANGER indicates a hazardous situation which, if not avoided, will result in death or serious injury.		
WARNING	WARNING indicates a hazardous situation which, if not avoided, could result in death or serious injury.		
CAUTION	CAUTION indicates a hazardous situation which, if not avoided, could result in minor or moderate injury.		
NOTICE	NOTICE indicates a situation that can result in property damage if not avoided.		
	<p>HIGH VOLTAGE WARNING! Indicates hazardous high voltages are present, which, if not avoided, will result in death or serious injury. Thus, only authorized and trained personnel should install and/or maintain this product.</p>		Hot surface
			Equipment grounding conductor
			Wait for a prescribed amount of time before engaging in the indicated action.

1.2 Safety Instructions

The inverter installation must be performed by an authorized electrician in accordance with the local and SAI Global AS/NZS 5033:2014.

- **CAUTION** - Risk of Electric Shock. When the PV array is exposed to light, it supplies a DC voltage to this equipment.
- **CAUTION** - Risk of Electric Shock. Do not remove cover. No user serviceable parts inside. Refer servicing to qualified service personnel.
- **CAUTION** - Risk of electric shock from energy stored in capacitor. Do not remove cover until 5 minutes after disconnecting all sources of supply.
- **WARNING** - For continuous protection against risk of fire, replace only with same type and ratings of fuse.
- **WARNING** - The RSD Combiner surfaces may become hot. To reduce the risk of burns, do not touch them.
- **CAUTION** - Electrical installation and final application in Australian market shall consider the requirements in AS/NZS 3000, AS/NZS 4777.1 and AS/NZS 5033.
- **CAUTION** - Although DC switch may be integrated in product already, external DC switches fulfill latest AS 60947.3 have to be installed out of the inverter in way per AS/NZS 5033.
- **CAUTION** - DRM function is carried out by external ancillary equipment eShow, please connect the equipment according to instruction strictly before use.

2 Introduction

With this device you have acquired a solar inverter for connection of photovoltaic systems to the grid. This solar inverter is characterized by an advanced housing design and state-of-the-art high-frequency technology, which enable the highest levels of efficiency.

The solar inverter includes series monitoring units, such as anti-islanding protection, display, RS485 (EIA485) interfaces.

The inverter is usable indoor and outdoor. It fulfills the directives of AS/NZS 5033, AS/NZS 4777, AS/NZS 4417, AS/NZS 3000 and IEC 62109 for parallel operation of power generation plants on low-voltage network of regional electrical utility companies.

The function of the anti-islanding protection (automatic isolation point for in-plant generation systems) stipulates compliance with the specifications of AS/NZS 4777 and IEC 62109.2.

In the following technical description, the precise functions are explained to the installer, as well as the user, which are required for the installation, operational start-up and handling of the solar inverter.

The inverter not only meets the safety requirements of AS/NZS 5033, but also complies with the specifications of AS/NZS 4777 for Grid Support Utility Interactive Inverters that support a more stable utility grid. Delta M TL series were testing to the AS/NZS 4777.2 and AS/NZS 4417 for Regulatory Compliance Mark.

In the following technical description, the precise functions are explained to the installer, as well as the user, which are required for the installation, operational start-up and handling of the solar inverter.

2.1 System

The content of renewable energy with respect to overall power consumption worldwide is increasing annually by approximately 25%. The reason for this rise can be primarily attributed to the constantly increasing demand for power, the increasing interest in environmentally friendly technologies, as well as the increasing costs of non-renewable energy.

By the use of renewable energy sources, the earth's atmosphere can be enormously relieved of increases in CO₂ and other harmful gases which result from power generation.

The solar inverter converts direct current from the solar cells into alternating current. This enables you to feed your self-produced solar energy into the public grid.

Thanks to efficient MPP tracking, maximum capacity utilization of the solar energy plant is ensured even in cases of misty and cloudy skies.

The string concept means that PV modules are always connected in series (in a string) and/or that strings with the same voltage are connected in parallel to the solar inverter with the aim of significantly reducing the photovoltaic system's cabling requirements.

The fact that the modules are connected in strings also means that the photovoltaic system can be perfectly matched to the solar inverter's input voltage range.

The inverter is transformer less type without galvanic isolation. Therefore, the inverter may only be operated with ungrounded PV arrays. Furthermore, the PV array must be installed in accordance with the AS/NZS 5033(Ungrounded Photovoltaic Power Systems) and the locally valid regulations for ungrounded PV arrays. Additionally, the PV array (PV modules and cabling) must have protective insulation and the PV modules used must be suitable for use with this inverter. PV modules with a high capacity to ground may only be used if their coupling capacity does not exceed 1,200 nF with 50Hz grid.

2.2 Data evaluation and communication

The integrated interface, processing and communication of the device enables easy operation of the solar inverter. Monitoring of the operational status and signaling of operational failures are capable of being called up over the interface. The data interfaces enable the downloading of data which can be evaluated with the aid of a PC system and allow continuous recording of operating data.

The best way of accessing this functionality is via a monitoring system connected to your inverter.

The read-out of the data over the integrated interface (RS485, BLE4.0, WIFI) is possible only in solar operation.

2.3 Technical structure of the solar inverter

The photovoltaic voltage is adjusted so that the maximum power output of the PV modules is also achieved with different solar irradiation levels and temperatures (MPP-Tracking). These inverters have quite wide MPP range of suit for variety of PV modules by a variety of manufacturers. Measures must be taken to ensure that the maximum no-load voltage of 600 V is never exceeded. Please note that the maximum no-load voltage will occur at the lowest temperatures anticipated. You will find more detailed information about temperature dependency in the data sheet for the PV modules.

The high-quality aluminum casing corresponds to protection degree IP65 and is protected by an anti-corrosion finish. The heat sink on the M series inverters is designed in such a way that operation of the inverter is possible at ambient temperatures from -22°F to +140°F (-30°C to +60°C) at full power and optimal efficiency for 230 Vac AC grids.

Metal fins designed into the rear side of the inverter chassis are used to dissipate heat and protect the unit. An internal temperature control protects the interior of the device. In case of high ambient temperatures, the maximum transferable power is limited.

The solar inverter is controlled by microcontrollers which provide interface communication and the values and messages on the front-panel display.

Operator protection requirements are met by electrically isolating the grid from the PV module. The electrical isolation between the grid and the PV module is equivalent to basic insulation. Maximum operator protection is ensured by reinforced isolation between the grid, PV modules and accessible interfaces (display, RS485 interface). Relevant standards concerning electromagnetic compatibility (EMC) and safety are fulfilled.

The solar inverter is functional in grid-parallel operation exclusively. An automatically anti-islanding function, which was accepted by a certification agency, guarantees secure disconnection in case of circuit isolation or interruptions in power supply and avoid isolated operation.

2.4 Ambient temperature

The inverter can be operated in an ambient temperature from -22 °F to 140 °F (-30°C to +60°C). The following diagram illustrates how the output power of the solar inverter is reduced automatically in accordance with ambient temperature.

The device should be installed in a well-ventilated, cool and dry location.

Due to tolerance of temperature sensor and efficiency difference under different PV voltage, this derating curve may be a little different from actual behaviors of unit.

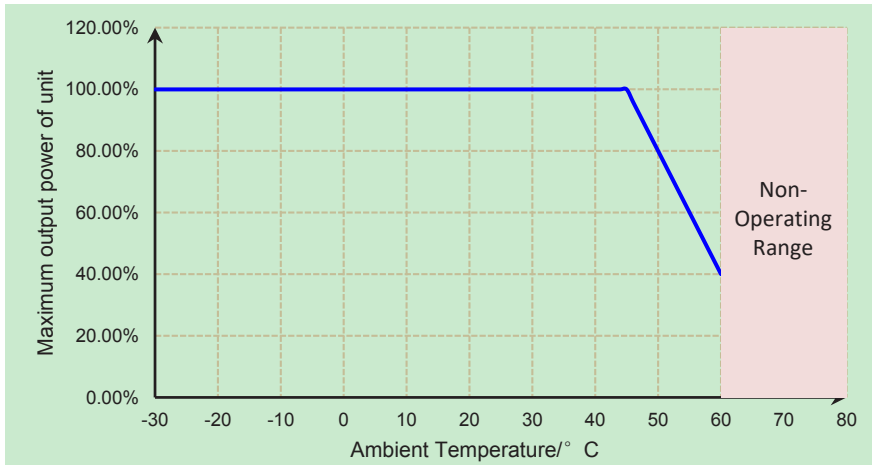

Figure 1: Typical derating curve of M series solar inverter

2.5 Solar inverter PV input DC voltage range

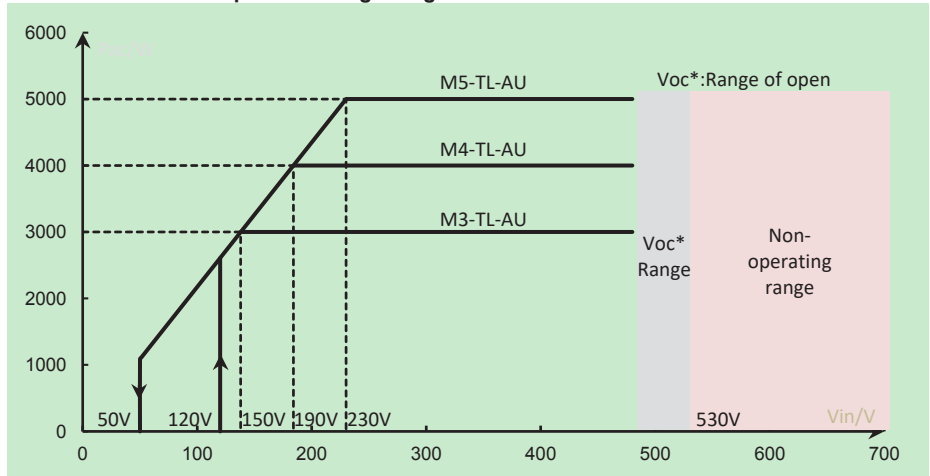

Figure 2: M5-TL DC voltage range

2.6 Efficiency

The best efficiency of the solar inverter is obtained at input voltages > 320V for 208V grid, and input voltages > 380V for 230V grid. The curve is obtained at 230V, 380V and 480V grid.

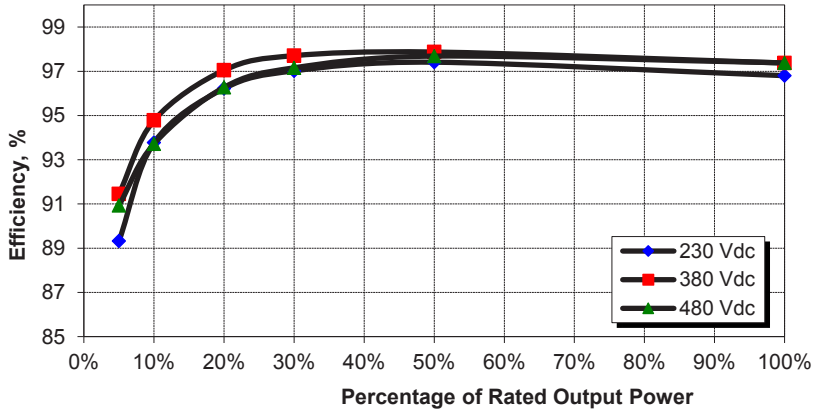

Figure 3: M5-TL efficiency plot

2.7 Equipment overview

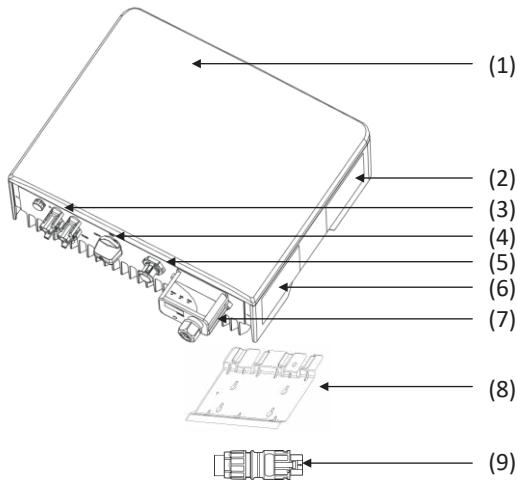

Figure 4. Exterior view of solar inverter main components

A further description of the equipment features:

(1) Inverter - This is the inverter section of the assembly. This section is sealed at the factory and

there are no user-serviceable parts inside. All wiring to install the inverter is done outside.

- (2) Product Label: Specification of product
- (3) PV Terminal: Terminal to connect to PV panel
- (4) DC Switch: Switch to operate or shutdown the inverter
- (5) AC Terminal: Terminal to connect to AC grid
- (6) Safety Label: Warnings and Information about safety operation
- (7) Communication Box - Inverter operation mode displays and communication (BLE 4.0/WIFI/RS485, optional) to outer device is provided.
- (8) Mounting Plate - The inverter ships with a mounting plate that allows easily assembly of the inverter to a wall
- (9) AC Connector: Connect to single phase AC grid line(LN) and ground line, plug it into the AC Terminal

2.8 Inverter type and safety labels

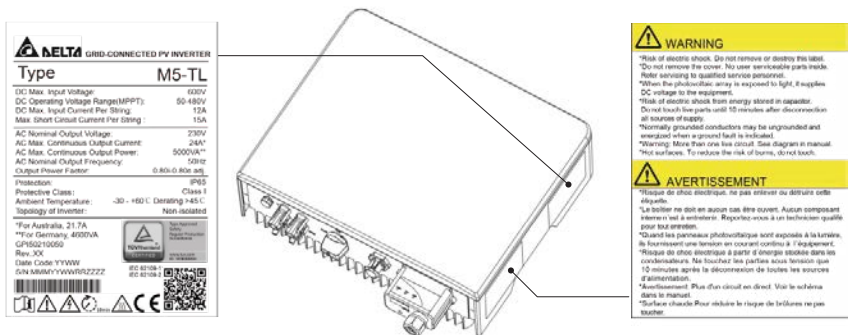

Figure 5. Labels location

The type label is shown in figure 5. Different type labels can be found on the M series TL inverter, the inverter serial number can be found on the type label. Please note that capital letters in Serial Number are used as placeholders to indicate the variable information for the inverter.

The main caution label in English is on the left side of the inverter.

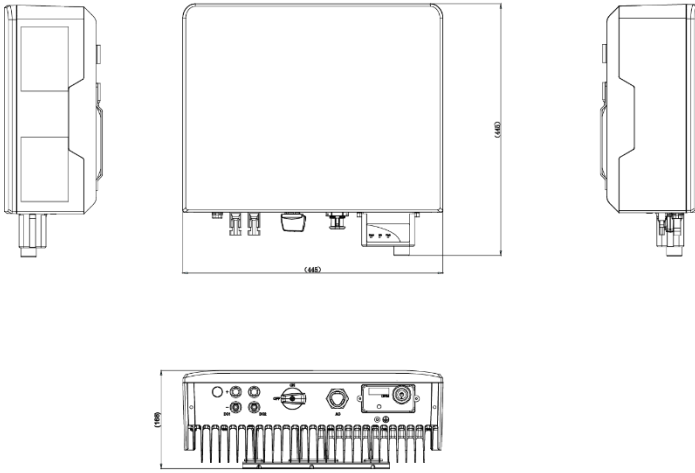

Figure 5. Dimensions of M series inverter

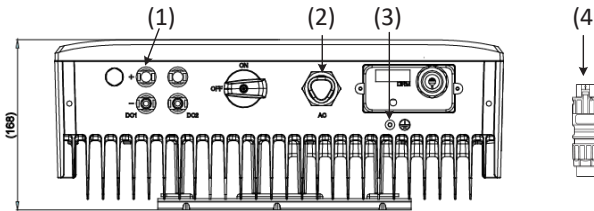

Figure 6. Wiring terminals of M series inverter

- (1) PV terminals
- (2) AC terminal (Output Side)
- (3) Grounding terminal
- (4) AC terminal (Wiring side)

The connection terminal is as below:

	Model	Manufacturer	Wiring (AWG)
AC terminal	PRC 3-FC-FS6 8-21-1410661	Pheonix	10
DC terminal MALE	32.0013P0001-UR	MC	14
DC terminal FEMALE	32.0012P0001-UR	MC	14

3 Installation



Read all of these instructions, cautions, and warnings for the Delta M series inverter and associated PV array documentation.



Installation and commissioning must be performed by a licensed electrician in accordance with local and SAI Global AS/NZS 5033:2014 requirements.



The installation and wiring methods used in the installation of this inverter. Australia must comply with all local, utility, SAI Global standards AS/NZS 5033:2014 and IEC 62109 requirements.



These servicing instructions are for use by qualified personnel only. To reduce the risk of electric shock, refer all servicing to factory qualified service personnel. No user service parts are contained inside the inverter.



The secondary short-circuit current rating is increased at the transfer connection point to the public electricity supply system by the nominal current of the connected solar inverter.



To reduce the risk of fire, connect only to a circuit provided with branch circuit overcurrent protection in accordance with AS/NZS 3000 requirements. PV overcurrent protective device with 20 A per string is necessary for inverter connection to PV panel.



This unit or system is provided with fixed trip limits and shall not be aggregated above 30KW on a single point of common connection.



In order to be able to carry out an energy measurement, a KWH revenue meter must be attached between the networks feed-in point and the solar inverter.

3.1 Visual inspection



All Delta M series inverters are 100% tested, packaged in a heavy duty cardboard shipping carton, and visually inspected before leaving our manufacturing facility. If you receive the inverter in a damaged shipping carton, please reject the shipment and notify the shipping company.

Verify Delta M series shipping carton contains:

- a. Correct Delta M series inverter model: M5-TL, M4-TL or M3-TL
- b. Mounting plate
- c. Quick Installation Guide
- d. AC terminal

Visually inspect the Delta M series inverter for any physical damage such as a bent heatsink fin and dented chassis.

If the inverter appears to be damaged or if the inverter needs to be returned, please contact your local Delta representative.



No user serviceable parts are contained in the inverter section.
Do not attempt to open or repair the inverter. The inverter section is factory sealed to maintain its IP65 rating and opening the top cover of the power head will void the inverter warranty.

3.2 Installation Information

1. Install the inverter on a non-flammable support base.
2. The inverter must be mounted vertically on a flat surface.
3. A minimum distance of 6 inches (15.2 cm) of unobstructed clearance on all sides to promote free convection is required.
4. Ensure the mounting hardware and structure can support the weight of the inverter.
5. Ensure the mounting hardware meets the appropriate building code.
6. Avoid installation on resonating surfaces (light construction walls etc.).
7. Installation can be indoors or in protected outdoor areas with shielding such as roof.
8. Avoid direct sun exposure.
9. Ensure inverter ambient temperature is within -22°F to +122°F (-30°C to +60°C) for optimal efficiency of the PV system.
10. Chose a mounting height for easy viewing of the display.
11. Despite having a IP65 enclosure certification, the inverter must not be exposed to heavy soiling.
12. Unused connectors and interfaces must be covered through sealing connectors.

3.3 Mounting the inverter

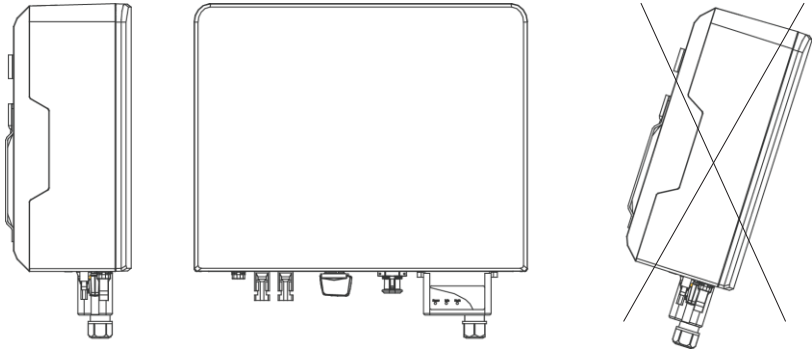

Figure 7. Mounting the inverter vertically

Please make sure the inverter is installed vertically, especially if it is to be installed outdoors.

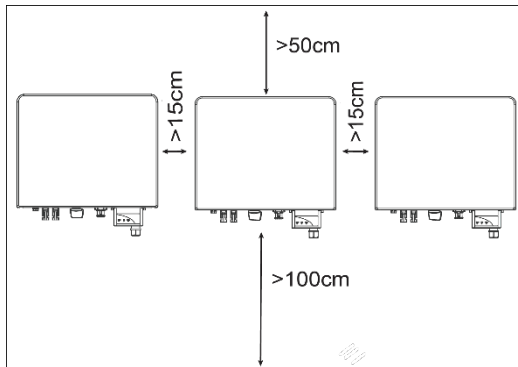

Figure 8. Inverter installation clearance

Please ensure the inverter is mounted with safe clearance and larger margin shall be left with higher ambient temperature.

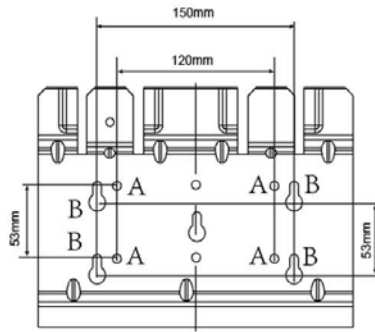

Figure. 9 Dimension drawing of mounting plate

1. Mount the mounting plate to the wall with at least 4 screws and anchors (\varnothing 6mm). With 4 screws use 4 holes A or 4 holes B (see Figure 9). You can use the mounting plate as a template for marking the positions of the boreholes.
2. Tighten the screws firmly to the wall.

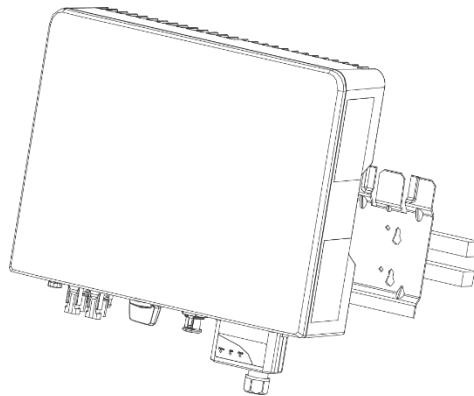

Figure 10. Mounting the plate and the inverter to the wall

1. Figure 13: Installing the plate and inverter on a wood stud wall Using the mounting plate as a template, mark four screw holes onto the wall. For 16 inches (40.6 cm) on center stud mounting, use the four holes that are indicated for this purpose in the figure. Make sure the holes are in the center of each stud before marking the drill location.
2. After marking the screw hole locations, drill the pilot holes for the appropriate screw type that will hold the weight of the inverter in the selected material. 1/4"lag bolts are recommended for mounting on wood framed walls.
3. Align the mounting plate over the pilot holes and install the mounting hardware to mounting surface. Please tighten to the recommended torque necessary to hold the mounting plate firmly to the wall surface type.
4. As the solar inverters are heavy, they should be lifted carefully.
5. With at least two persons on either side of the inverter, lift it up and place it carefully onto the mounting plate. Install two screws as shown in the figure 9 to secure the

device.

6. Check that the solar inverter is seated securely on the wall.

It is recommended to use stainless steel screws, especially if installed outdoors. Be sure to verify sheer and pullout strength of anchors or other wall attachments.

3.4 Electrical connection

- Electrical connections shall conform to the installation specifications of the country/region where the equipment is located.
- Make sure the PV and AC side are disconnected before connecting, otherwise the high voltage of the inverter may lead to electric shock hazard.

Connect the PV terminal:

- Connect the PV terminal of the panel side to the PV terminal of the inverter side.
- Make sure the cable polarity is correct before the PV connection.
- When the click like “clatter” is heard, the input wire can't be pull-out by hand, the connection is successful.

Connect the AC terminal:

- Cross-sectional area of the wire: 4mm²-6mm²
- Applicable outer diameter of the cable: 8mm²-21mm²

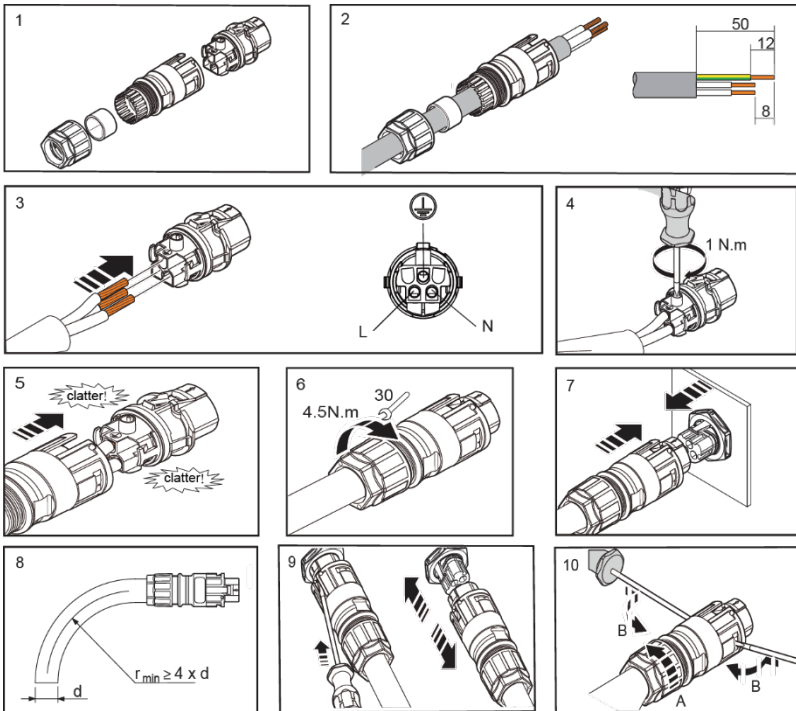

Figure 11. Install AC terminal

3.5 Install protective ground wire

- The inverter housing is grounded, as shown in Fig.12
- Cross-sectional area of wire: 4mm²-6mm².
- Screw torque: 1.4 N.m

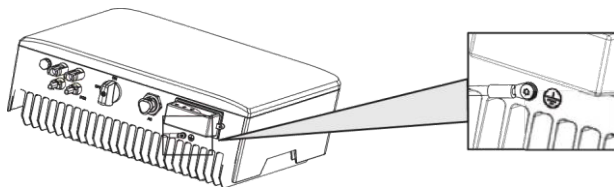

Figure 12 Protective grounding

4 Electrical connections

4.1 General safety



Read all of these instructions, cautions, and warnings for the Delta M series inverter and associated PV array documentation.



Installation and commissioning must be performed by a licensed electrician in accordance with local, state, and AS/NZS 5033 requirements. Use AWG14 for PV wiring and AWG10 for AC wiring or greater 90°C (194 °F), copper solid or stranded wire for all DC and AC wiring to the M series inverter to optimize system efficiency.



PV solar arrays produce hazardous voltages and currents when exposed to light which can create an electrical shock hazard. Using dark opaque sheets cover the PV solar array before wiring or connecting cable terminations.



Before connecting the Delta M series inverter to the AC distribution grid, approval must be received by appropriate local utility as required by national and state interconnection regulations, and must be connected only by qualified personnel.



Do not attempt to open or repair the inverter as the inverter is factory sealed to maintain its IP65 rating and will void the inverter warranty.



The PV AC output circuits are isolated from the enclosure. The PV system PE Conductor when required by AS/NZS 3000.

4.2 AC grid connection

M series TL AU inverters are designed for single phase grid. Nominal voltage is 230 V_{ac}, frequency is 50 Hz. Other technical requests should comply with the requirement of the local public grid.

4.3 External DC switch

Although DC switch may be integrated in product already, external DC switches fulfill latest AS 60947.3 have to be installed out of the inverter in way per AS/NZS 5033. External DC switch capacity shall be no less than 20 A per string.

4.4 AC circuit breaker requirements

A dedicated circuit breaker in the building circuit panel is required for each Delta M series inverter that is installed. There should be a circuit breaker or fuse to protect each AC line, L and N. The circuit breaker should be able to handle the rated maximum output voltage and current of the inverter. Please refer to the table below to determine the appropriate circuit breaker size to avoid potential fire hazards. The SAI Global AS/NZS 5033 or applicable local electrical codes must be followed when determining maximum branch-circuit over-current protection requirements.

Inverter model	Recommended AC branch protection
M3-TL	2-pole, 20 A 230 Vac
M4 -TL	2-pole, 25 A 230 Vac
M5 -TL	2-pole, 30 A 230 Vac

Please note that there is an exception to the requirement of a dedicated circuit breaker in the building circuit panel for each inverter if there exists a dedicated PV system AC subpanel that is used to combine multiple inverters. In this case, only one breaker at the main building service panel should be installed for a multiple inverter installation utilizing a dedicated PV system AC subpanel.

4.5 Grounding conductor

Per AS/NZS 5033, a grounding conductor must be installed, and the PE conductor must be sized in accordance with AS/NZS 3000. The grounding conductor should be terminated at the PE screw terminal inside the wiring box compartment. Grounding wire shall be selected based on the local rules and its diameter is no less than 4 mm². Green, yellow double color line is recommended for protective grounding and secondary grounding terminal at the bottom of inverter shall be reliable grounded as well as the grounding inside AC terminal, or personal injury may be caused.

4.6 Lightning and surge protection

Delta M series AU inverters are designed and certified to meet stringent AS/NZS 4777 and IEC 62109-2 AC lightning and surge requirements; however, every PV installation is unique, thus additional external AS/NZS AC and DC surge protection and solid grounding practice is recommended

4.7 Multiple inverters

Multiple Delta M series inverters are permitted at a common location if all applicable SAI global, local building codes and local utility commissioning guidelines are met. In addition, each inverter should have its own dedicated AC branch protection circuit breaker and a dedicated PV string/array, not to exceed the inverter's ratings.

4.8 PV string considerations

There are a large number of PV module string combinations that will offer optimal performance from either the M3-TL-AU, M4-TL-AU and M5-TL-AU inverters thanks to its wide full power MPP range (50 V – 48'0 V)

1



Follow the temperature multiplication factors given in AS/NZS 5033 table and the PV module manufacturer specified V/Temp coefficient to ensure PV string voltage is less than < 600 Vdc. Maximum inverter PV input voltage for all possible weather conditions in the location of installation.



System wiring voltage losses should be no greater than 1 to 2 percent for optimal system efficiency and performance.

4.9 Inverter connections

4.9.1 General information



Installation and commissioning must be performed by a licensed electrician in accordance with local, state, and AS/NZS 3000 requirements.



Inputs and output circuits of this unit are isolated from the enclosure. System grounding must be done in accordance with the AS/NZS 3000 and Compliance is the responsibility of the installer.



Ensure no live voltages are present on PV input and AC output circuits, and verify that the DC disconnect, AC disconnect, and dedicated AC branch circuit breaker are in the “OFF” position, before inverter installation.



PV solar arrays produce hazardous voltages and currents when exposed to light which can create an electrical shock hazard. Using dark opaque sheets cover the PV solar array before wiring or connecting cable terminations



Before any electrical wiring can be connected to the inverter, the inverter must be permanently mounted.



Use solid or stranded copper conductors only. AWG14 for PV, AWG10 for AC, is recommended wire size.



Inverter warranty is VOID if the DC input voltage exceeds the inverter 600 Vdc maximum.

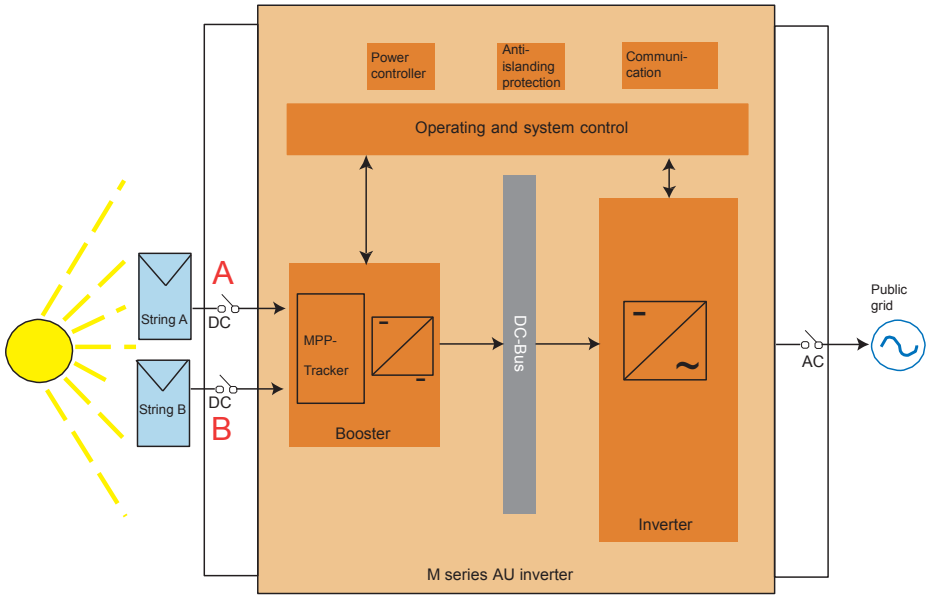

Figure 11: M series TL Inverter electrical diagram

4.9.2 PV array string input connections



To ensure maximum protection against hazardous contact voltages while assembling photovoltaic installations, both the positive and the negative leads must be strictly isolated electrically from the protective ground potential (PE).



Verify DC conductor voltage polarity with voltage meter because damage to the inverter could result if incorrect DC input polarity is connected.

Risk of damage. Be sure that the polarity is correct when you make the connection. Connecting it wrongly will cause damage to the inverter.



Risk of electric shock and fire. Use only with PV modules with a maximum system voltage of rating of 600V or Higher.

Electric shock hazard. The DC conductors of this photovoltaic system are ungrounded and may be energized.



Electric shock hazard. The DC conductors of this photovoltaic system are ungrounded but will become intermittently grounded without indication when the inverter measures the PV array isolation.



The PV Array positive or negative leads must not be connected to ground before the inverter!

INFORMATION!
INFORMATIONS!

All screw terminals accept solid or stranded copper 14 – 6 AWG wire only.

INFORMATION!
INFORMATIONS!

4.9.3 Inverter AC output wire connections



- Read all of the instructions, cautions, and warnings for the Delta M Series Inverter, associated PV array documentation.
- Installation and commissioning must be performed by a licensed electrician in accordance with local, state, and AS/NZS 3000 requirements.
- Ensure no live voltages are present on PV input and AC output circuits, and verify that the DC disconnect, AC disconnect, and dedicated AC branch circuit breaker are in the “OFF” position, before inverter installation.
- Verify that dedicated 2-pole 230 Vac circuit breaker in the building electrical service panel is turned-off.

5 Commissioning the PV system



Read all of these instructions, cautions, and warnings for the Delta M series inverter and associated PV array documentation.



Installation and commissioning must be performed by a licensed electrician in accordance with local, state, and AS/NZS 4777 requirements.



Verify that the dedicated 2-pole 230 Vac circuit breaker in the building electrical service panel is turned-off.



Disconnect in the “OFF” position, verify the PV input polarity once more simply by carefully using a 600 V, DC rated digital volt meter and probing the positive (+) and negative (-) PV array connections.

5.1 Status LEDs

Label	Designation	Color
<i>Power</i>	Operation	Green
<i>Fault</i>	Fault	Red
<i>Info</i>	Information	Yellow

Information on the LED messages is provided in “8. Diagnosis and maintenance”.

5.2 LED Indication

5.2.1 Introduction

Function

There are 3 LEDs in the front side of the inverter

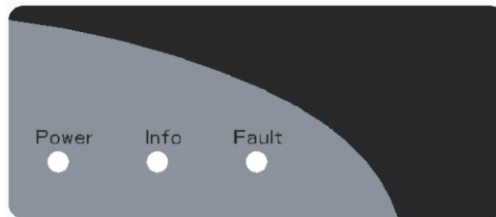

5.2.2 LED Message

The LEDs indicate the operational status of the inverter

Message Category	LED Signal				Message Explanation
	LED	Color	Status	Behavior	
Normal Operating	POWER	Green	<On>	Constant on	The inverter feeds in grid.
Sync.	POWER	Green	<Blink>	1s on, 1s off	The inverter is synchronizing with grid.
Information	INFO	Yellow	<On>	Constant on	The inverter has alarm and user can search for details via APP.
Grounding fault	FAULT	Red	<On>	Constant on	Grounding fault occurs.
Inverter fault	FAULT	Red	<On>	Constant on	The inverter has fault and user can search for details via APP.
Firmware upgrade	POWER	Green	<Blink>	0.5s on, 0.5s off	The inverter is under firmware upgrade.
	INFO	Yellow	<Blink>	0.5s on, 0.5s off	
Initialization	POWER	Green	<On>	On until done	Inverter initialize when the DC voltage rise to startup threshold.
	INFO	Yellow	<On>	On until done	
	FAULT	Red	<On>	On until done	

5.3 Inverter turn-on procedure

Compatibility

1. Turn on the DC disconnect (turn to “ON” position, if rapid shutdown device is connected turn on AC disconnect firstly).
2. Check for inverter initialization (all three LED indicators are illuminated).
3. Turn on the dedicated 2-pole 230Vac circuit breaker in the building electrical service panel (put in closed position).
4. If there is AC disconnect, turn on the AC disconnect.
5. Refer to section 6 for setup process that needs to be completed before the inverter can begin feeding power to the grid.

5.4 Inverter turn-off procedural

1. If there is AC disconnect, turn off the AC disconnect.
2. Turn off the dedicated 2-pole 230Vac circuit breaker in the building electrical service panel (put in open position).
3. Turn off the DC disconnect (turn to “OFF” position).

5.5 M Series APP(Android) Manual

5.5.1 Introduction

Function

M Series APP is a mobile application software to communicate with inverter system for real-time status monitoring, parameter configuration, RMA request form generating and daily maintenance via Bluetooth Low Energy.

5.5.2 Installation

Compatibility

1. Requires android 4.4(KitKat) or later.
2. BLE supported.
3. Internet over WIFI.

Procedure

Search “M Tool” in Google Play, download and install the application.

The app icon will show up on the desktop.

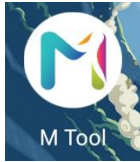

5.5.3 Connection

Procedure

- Step 1. Open app, allow all the permissions required.
- Step 2. Close guide page, guide page only shows at the first time.
- Step 3. Click on  to refresh and display device list.

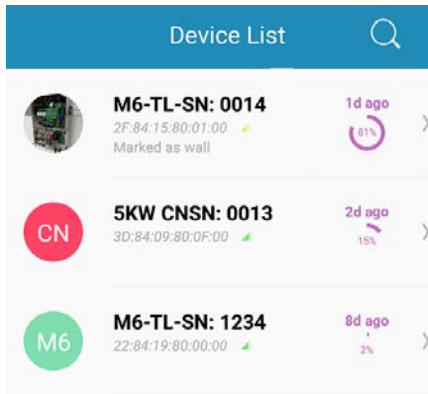

- Step 4. Connect the device with the following method:

Press on  to get connection with it.

- Step 5. Wait in the monitor page until the progress bar finish and disappear.

5.5.4 Menu Structure

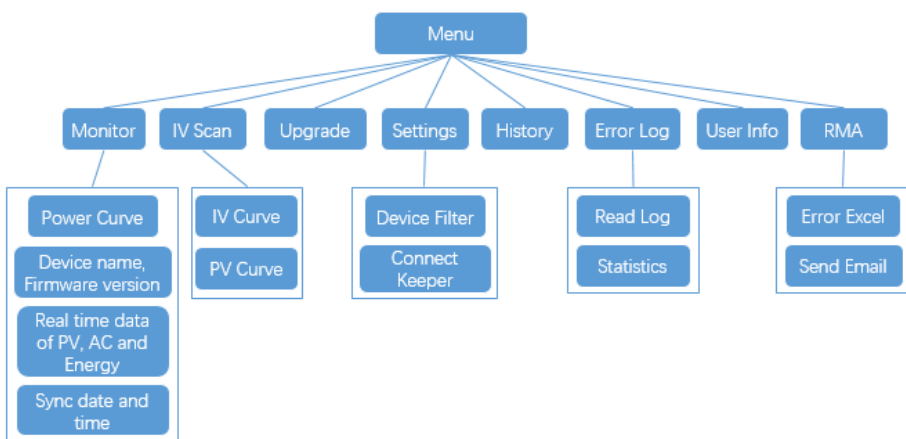
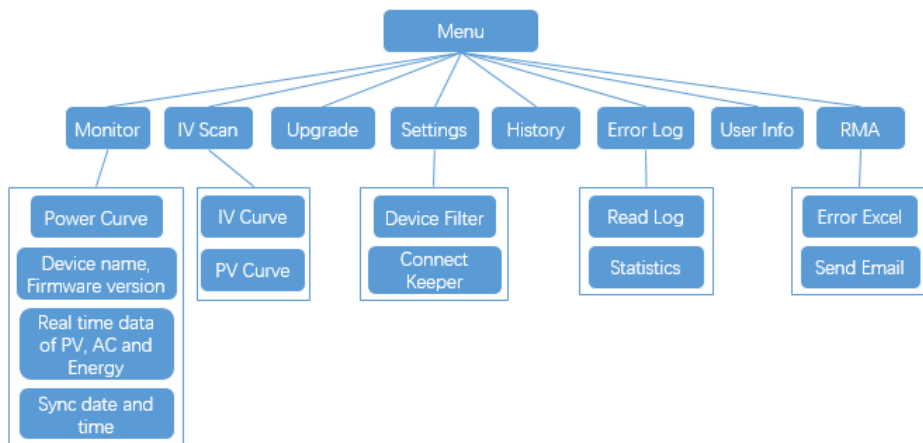

5.5.5 Functions

5.5.5.1 Monitor - Display Real-time Status and Power Curve

Procedure

Step 1. After connecting device, monitor page will show real-time status of today, including power curve, PVs voltage, PVs current, AC voltage, AC current, energy and instant power. It will show device name and firmware version, and synchronize date and time automatically.

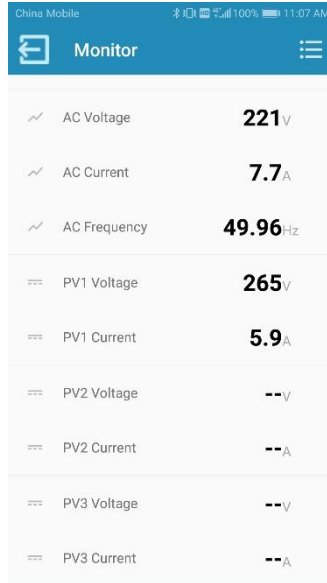

5.5.5.2 IV Scan

Step 1. Press on  to display menu.

Step 2. Press on "IV Scan"

Step 3. Select a PV button to click, wait until the dialog disappear to show IV curve and PV curve.

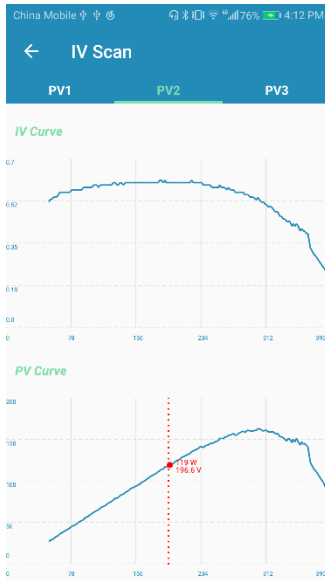

5.5.5.3 Configuration

Press “App Settings” to enter configuration. Configuration contains basic settings and other settings.

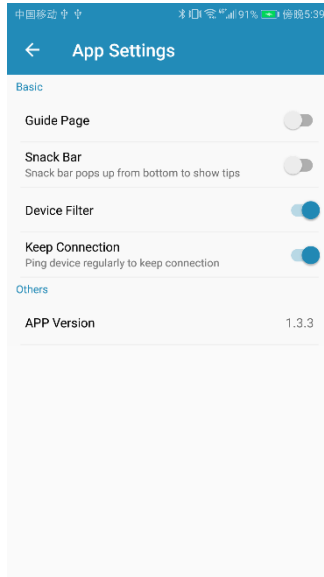

Basic



- 1 **Enable Guide**
Guide page shows only once at the first time, enable the switch to show it one more time.
- 2 **Enable Snack Bar**
Snack bar pops up from the bottom of screen to show some tips. Click the switch to enable or disable it.
- 3 **Enable Device Filter**
Device filter allows the scanner to ignore the irrelevant devices. Click the switch to enable or disable it.
- 4 **Keep Connection**
Connection interruption will occur if the connection is not active in a period of time. Keep connection allows app to send pin message to device regularly to avoid interruption. Click the switch to enable or disable it.

Others

- 1 **Version**
Show current version number.

5.5.5.4 Error Log



Procedure









- Step 1 Click on  button to back to monitor.
- Step 2 Press on  to display menu.
- Step 3 Press on "Error Log"
- Step 4 Press on "Read Log"

China Mobile 中国移动		64% 1:10 PM	
← Log			
2018/04/11 11:11:24	normal operation		
Safety Error		274	
Frequency high			N/D
2018/04/11 11:36:49	normal operation		
Safety Error		274	
L12 under voltage			470
2018/04/13 13:37:59	normal operation		
Remote Off			N/D
2018/04/13 13:49:09	normal operation		
Remote Off			N/D
2018/04/13 14:29:05	normal operation		
Remote Off			N/D
2018/04/13 14:39:39	Startup		
Safety Error		274	
L12 under voltage			470
2018/04/17 16:40:47	normal operation		
Remote Off			N/D
2018/04/19 09:37:29	normal operation		
Safety Error		274	
AFCI fault			439
2018/04/19 09:40:15	normal operation		
Safety Error		274	
AFCI fault			439
2018/04/19 09:50:10	normal operation		

5.5.5.5 History – Display PV and AC History



Procedure

- Step 1 Click on  to back to monitor.
- Step 2 Press on  to display menu.
- Step 3 Press on “History” to check history data.

History		
AC		
	Max Active Power	3735_W
	Max Voltage	231_V
	Max Current	17_A
	Max Reactive Power	N/A_{Var}
PV1		
	Max Power	3687_W
	Max Voltage	336.0_V
	Max Current	13.2_A
PV2		
	Max Power	2146_W

5.5.5.6 User Information

Procedure

- Step 1 Click on  to back to monitor.
- Step 2 Press on  to display menu.
- Step 3 Press on “Edit” to enter user info page.
- Step 4 Edit user information.

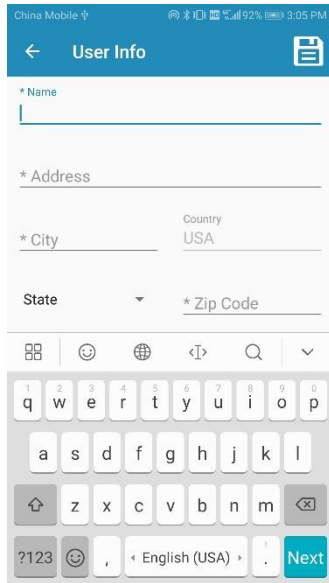

Step 5 Click on “Save” to save data.

5.5.5.7 Update

Procedure

Step 1 Click on  to back to monitor.

Step 2 Press on  to display menu.

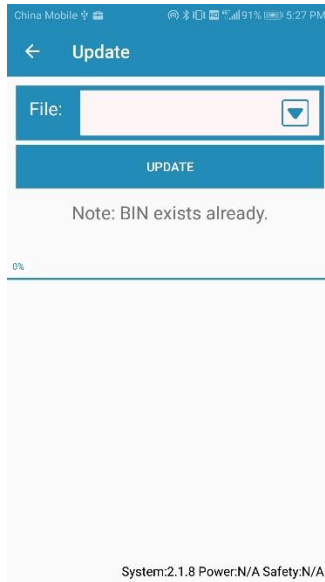

Step 3 Press on “Upgrade” to enter upgrade page.

Step 4 Pick one BIN file to update.



5.5.5.8 RMA

Procedure

- Step 1 Click on  to back to monitor.
- Step 2 Press on  to display menu.
- Step 3 Press on “RMA” to enter RMA page.
- Step 4 Complete user info if it shows “incomplete”
- Step 5 Click on RMA button.
- Step 6 Pick your email app and send email.

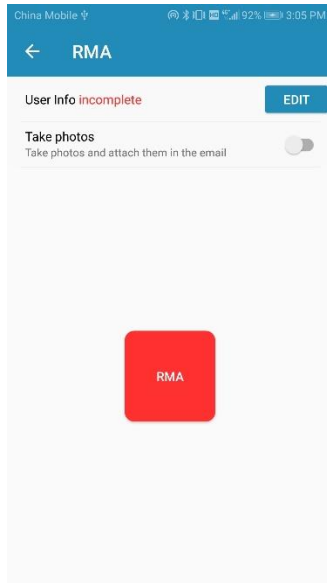

6 Production information



All production information is provided for orientation purposes only. The measuring devices and meters provided by the electricity supply company are the authoritative source of information for invoicing.

7 Repair



Danger of death from hazardous voltage.

Hazardous voltage is applied to the solar power inverter during operation. Hazardous voltage is still present 5 minutes after all power sources have been disconnected.

Never open the solar power inverter. The solar power inverter contains no components that are to be maintained or repaired by the operator or installer. Opening the cover will void the warranty.



The solar power inverter contains no components that are to be maintained by the operator or installer.

8 Decommissioning, transport, storage, disposal



Danger of death or severe injuries from dangerous voltage

Disconnect the solar inverter from the grid before removing or inserting the AC connector.



Danger of death or severe injuries from dangerous voltage

Dangerous voltages can be present at the DC connections of the solar power inverter.

Never disconnect the PV modules when the solar power inverter is under load. First switch off the grid connection so that the solar power inverter cannot feed energy into the grid. Then open the DC disconnecter.

Secure the DC connections against being touched.



Danger of injury due to heavy weight

The solar power inverter is heavy (see “9.2 Technical data”). Incorrect handling can lead to injuries.

The solar power inverter must be lifted and carried by two people.

8.1 Decommissioning

1. Switch off the AC cable to be free of voltage.
2. Open the DC disconnecter.
3. Remove all cables from the solar power inverter.
4. Unscrew the solar power inverter from the wall bracket.
5. Lift the solar power inverter from the wall bracket.

8.2 Packaging

Use the original packaging or packaging of the same quality.

8.3 Transport

Always transport the solar power inverter in the original packaging or packaging of the same quality.

8.4 Storage

Always store the solar power inverter in the original packaging or packaging of the same quality. Observe the specifications relating to storage conditions described in chapter "9.2 Technical data".

8.5 Dispose

Dispose of the solar power inverter in a technically appropriate manner according to the legal requirements of your country.

9 Certificate and technical data

9.1 Certificate

Please check our web site at: <http://www.delta-americas.com/SolarInverters.aspx> for the most recent certificates.

9.2 Technical data

Model	M3-TL-AU	M4-TL-AU	M5-TL-AU
Input(DC)			
V _{MAX} PV		600 V	
Nominal voltage		380 V	
Max. Operating Voc		530 V	
Operating MPP voltage range		50 ~ 480 V	
Full Power MPP voltage range	150~480 V	190~480 V	230~480 V
Max. Input current (Per String)		12A	
Max. short circuit current @ STC		15A/15A	
Start PV voltage		120 V	
Stop PV voltage (PCE shutdown)		50 V	
Backfeed current		0	
Allowed DC loading ratio		1.5	
Overvoltage category		II	
DC disconnect		Internal	
MPP tracker	2	2	2
Input strings available	1-1	1-1	1-1

Output(AC)

Model	M3-TL-AU	M4-TL-AU	M5-TL-AU
Nominal power	3000 W	4000 W	5000 W
Maximum output power	3000 W	4000 W	5000 W
Maximum output power	3000 VA	4000 VA	5000 VA
Operating voltage range	180~275 V		
Rated output voltage	230 V		
Max continuous current	16A	20A	24 A(21.7 A for AU)
Maximum output overcurrent protection	25 A	30 A	35 A
Maximum inrush current	5 A	5 A	5 A
Maximum output fault current	18 A	24 A	32 A
Nominal frequency	50 Hz		
Operating frequency range	45.0 ~ 55.0 Hz		
Standby power consumption	< 10 W		
Night consumption	< 1 W		
iTHD @ nominal power	< 3%		
Acoustic noise	40 dB		
Overvoltage category	III		
Power factor @ nominal power	> 0.99		
Adjustable power factor range	0.80i ~ 0.80c		

Model	M3-TL	M4-TL	M5-TL
PV & GRID CONNECTION			
Array insulation resistance detection	500 kΩ (> V _{MAX} PV/30 mA)		
Continuous residual current threshold value	250 mA (I _{LIMIT} : 300 mA)		
Continuous residual current trip time	180 ms(T _{LIMIT} : 300 ms)		
Sudden residual current threshold value	20 mA(I _{LIMIT} : 30 mA)	50 mA (I _{LIMIT} : 60 mA)	130 mA (I _{LIMIT} : 150 mA)
Sudden residual current trip time	180 ms (T _{LIMIT} : 300 ms)	50 ms (T _{LIMIT} : 150 ms)	0 ms (T _{LIMIT} : 40 ms)

CONSTRUCTION

Model	M3-TL	M4-TL	M5-TL
Type of inverter	Non-isolated		
Type of NS protection	Integrated		
Separated by	Transformerless		
Protective class	I		
Max. efficiency	98%		
Pollution degree	PD 3		
CEC efficiency	97.2% @ 230V		
Operating temperature range	"-30 ~ 60°C derating above 45°C"		
Storage temperature range	-40 ~ 185°F (-40 ~ 85°C)		
Humidity	4 ~ 95%		
Max. operating altitude	3000 m		

Model	M3-TL	M4-TL	M5-TL
MECHANICAL DESIGN			
Size L x W x D inches (L x W x D mm)	17.7 x 15 x 6.3 in. (450 x 383 x 160)		
Weight	33 lbs (15 kg)		
Cooling	Natural Convection		
AC connectors	Spring terminals in connection box		
Compatible Wiring Gauge in AC	AWG 10 ~ AWG 6		
DC connectors	BLE 4.0, RS485/WiFi (Optional)		
Compatible Wiring Gauge in DC	Diecast Aluminum and Plastic		
Communication interface	Compatible with battery		
Model	M3-TL	M4-TL	M5-TL
STANDARDS / DIRECTIVES			
Enclosure protection rating	IP65		
Safety	AS/NZS 4777, IEC 62109-1, IEC 62109-2		
EMC	IEC 61000-6		
Anti-islanding Method	Reactive Power Injection		
WARRANTY			
Standard warranty	5 years		

Delta Electronics Australia Pty Ltd.

Melbourne Main Office :

Unit 20-21, 45 Normanby Road, Notting Hill VIC 3165, Australia

Sydney Office:

**B46/24-32 Lexington Drive, Bella Vista NSW 2153,
Australia**

Tel: +61 3 9543 3720

Fax: +61 3 9544 0606

Service Line : 1300 DELTA E (1300 333823) 24/7

Service Support email: Solarsupport@deltaww.com

10 Warranty

The M series grid-tied inverter includes a standard 5-year warranty in effect from the time your inverter is commissioned. For all the M series AU warranty terms and return procedures, please refer to our web site at <http://www.delta-americas.com/SolarInverters.aspx> for further information.

For assistance with warranty repairs or returns you may contact our North America support hotline at: 1-877-442-4832 or via email at support.usa@solar-inverter.com.

11 Glossary

AC

Abbreviation for "Alternating Current".

Anti-islanding protection

This is a unit for grid monitoring with assigned switching elements (anti-islanding protection) and is an automatic isolation point for small power generation systems (to 30 kWp).

Basic Insulation

Insulation to provide basic protection against electric shock.

CEC

Abbreviation for the California Energy Commission

CEC Efficiency

CEC Efficiency is the California Energy Commission Efficiency rating, a performance rating for modules and inverters based on the real environment that a system will be in.

CSA

Abbreviation for the Canadian Standards Association.

DC

Abbreviation for "Direct Current".

EMC

The Electro-Magnetic Compatibility (EMC) concerns the technical and legal basics of the mutual influencing of electrical devices through electromagnetic fields caused by them in electrical engineering.

Galvanic isolation

No conductive connection between two component parts.

GND

Ground

IEEE

The Institute of Electrical and Electronics Engineers or IEEE (read I-Triple-E) is an international non-profit, professional organization for the advancement of technology related to electricity.

Initialization

Under initialization (cf. English to initialize) is understood the part of the loading process of a program, in which the storage space required for the execution (e.g. variable, code, buffers ...) for the program is reserved and is filled with initial values.

Local utility company

A local utility company is a company which generates electrical energy and distributes it over the public grid.

MPP

The Maximum Power Point is the point on the current-voltage (I-V) curve of a module, where the product of current and voltage has its maximum value.

Nominal power

Nominal power is the maximum permissible continuous power output indicated by the manufacturer for a device or a system. Usually the device is also optimized so that the efficiency is at its maximum in case of operation with nominal power.

Nominal current

Nominal current is the absorbed current in case of electrical devices if the device is supplied with the nominal voltage and yields its nominal power.

PE

In electric systems and cables a protective earth conductor is frequently employed. This is also called grounding wire, protective grounding device, soil, grounding or PE (English „protective earth“).

Photovoltaics (abbr.: PV)

The conversion of PV energy into electrical energy.

The name is composed of the component parts: Photos - the Greek word for light - and Volta - after Alessandro Volta, a pioneer in electrical research.

Power dissipation

Power dissipation is designated as the difference between absorbed power and power of a device or process yielded. Power dissipation is released mainly as heat.

PV cell

PV cells are large-surface photodiodes which convert light energy (generally sunlight) into electrical energy. This comes about by utilization of the photoelectric effect (photovoltaics).

PV generator

System comprising of a number of PV modules.

PV module

Part of a PV generator; converts PV energy into electrical energy.

RS485 (EIA485)

Differential voltage interface on which the genuine signal is transmitted on one core and the negated (or negative) signal on the other core.

Separate grid system

Energy supply equipment which is completely independent of an interconnected grid.

Solar inverter

is an electrical device which converts DC direct voltage into AC voltage and/or direct current into alternating current?

String

Designates a group of electrical PV modules switched in series.

String solar inverter (solar inverter concept)

The PV generator is divided up into individual strings which feed into the grid over their own string solar inverters in each case. In this way, the installation is considerably facilitated and the gain decrease, which can arise from the installation or from different shading conditions of the PV modules, is considerably reduced.

Voc

Open Circuit Voltage

Note

Delta Products Corporation, Inc.

46101 Fremont Blvd.

Fremont, CA 94538

Sales Email: Inverter. Sales@deltaww.com

Support Email: Inverter. Support@deltaww.com

Sales Hotline: +1-877-440-5851 or
+1-626-369-8021

Support Hotline: +1-877-442-4832

Support (Intl.): +1-626-369-8019

Monday to Friday from 7am to 5pm PST (apart from Holidays)

www.delta-americas.com/solarinverters

