



Grid-tie Transformerless Solar Inverter

M15A_220 / M20A_220
Operation and Installation Manual

English 1

繁體中文 63

www.deltaww.com

 **DELTA**
Smarter. Greener. Together.

Contents

- 1 Safety 8**
 - 1.1 Information of the Inverter 8
 - 1.1.1 Legal Provisions 8
 - 1.1.2 Target Group 8
 - 1.2 General Safety 9
 - 1.2.1 Condition of Use 9
 - 1.2.2 Symbols 10
- 2 Introduction 12**
 - 2.1 Valid Model 12
 - 2.2 Product Overview 13
- 3 Installation 16**
 - 3.1 Unboxing & Review 17
 - 3.2 Vertical wall mount 19
 - 3.3 Electrical Installation for AC Wiring 22
 - 3.3.1 AC Grid Types and Connections 23
 - 3.3.2 Required Protective Devices 23
 - 3.3.3 Multiple Inverters in Parallel Connection 23
 - 3.3.4 AC Wiring Preparation 24
 - 3.3.5 AC Wiring 25
 - 3.4 Electrical Installation for DC Wiring 27
 - 3.5 Equipment Grounding 30
 - 3.6 Communication Module Connections 31
 - 3.6.1 Accessing the Communication Module 32
 - 3.6.2 RS-485 Connection 33
 - 3.6.3 EPO Function & Digital Input 35
 - 3.6.4 Dry Contact Connection 36
 - 3.6.5 Rapid Shutdown System Connection (optional) 36
 - 3.7 Wi-Fi 37

- 4 Commissioning 38**
 - 4.1 LED Signals 38
 - 4.2 Auto ID Commission 39
 - 4.2.1 Commission Setting (DSS) 39
 - 4.2.2 Scan inverter 40
 - 4.2.3 Set ID 41
 - 4.2.4 Set Country 42
 - 4.2.5 Synchronize time 42
 - 4.3 Delta Function Setting 43
- 5 Maintenance 44**
 - 5.1 Open and Close the Door 44
 - 5.1.1 Open Door 44
 - 5.1.2 Close Door 45
 - 5.2 Replacement of Surge Protection Devices (SPD) 46
 - 5.2.1 Replace AC SPD 47
 - 5.2.2 Replace DC SPD 48
 - 5.3 De-Commissioning 50
- 6 Error Message and Trouble Shooting 51**
 - 6.1 Error Codes (Field Fault) 51
 - 6.2 Fault Codes (Inverter Fault) 52
 - 6.3 Warning Codes (Field Warning) 54
 - 6.4 Warning Codes (Inverter Warning) 54
 - 6.5 Earth Fault Alarm 54
- 7 Technical Information 55**
- Appendix: Assembly Note 61**

Figure

- Figure 2-1: Components 13
- Figure 2-2: Overview 14
- Figure 2-3: Rating label 15
- Figure 3-1: Steps to unpacke the inverter 17
- Figure 3-2: Attaching the Hoisting hooks 18
- Figure 3-3: Inverter dimensions 18
- Figure 3-4: Mounting bracket dimensions 20
- Figure 3-5: Positions of mounting screws 20
- Figure 3-6: Separation distance of plural inverters 21
- Figure 3-7: Permitted and prohibited mounting positions 21
- Figure 3-8: Strip the wires 24
- Figure 3-9: Assemble the AC plug 25
- Figure 3-10: The rubber rings of AC gland 25
- Figure 3-11: AC wiring 26
- Figure 3-12: Rotate the AC plug to fit 26
- Figure 3-13: DC wiring illustration 28
- Figure 3-14: Location of H4 connectors to connect array wiring (DC) 29
- Figure 3-15: Mount the equipment grounding 30
- Figure 3-16: Communication module layout 31
- Figure 3-17: Location and access to communication module 32
- Figure 3-18: Multiinverter connection illustration 34
- Figure 3-19: EPO and digital input function terminal block 35
- Figure 3-20: Dry Contact connection 36
- Figure 3-21: Rapid Shutdown System connection 36
- Figure 3-22: Installation of Wi-Fi antenna 37
- Figure 4-1: LED indicators 38
- Figure 4-2: DSS Commission setting 39
- Figure 4-3: Steps of scanning inverters 40
- Figure 4-4: Steps of ID setting 41
- Figure 4-5: Steps of country setting 42
- Figure 4-6: Steps of time synchronization 42

Figure 5-1: Open and close the door 44

Figure 5-2: To secure door by hexagon driver 45

Figure 5-3: Location of AC and DC SPD board 46

Figure 5-4: AC and DC SPD module 46

Figure 5-5: Steps of changing AC SPD 47

Figure 5-6: Remove wirings as connectors of AC SPD 47

Figure 5-7: Steps of changing DC SPD 48

Figure 5-8: Remove wirings as connectors of DC SPD 49

Figure 7-1: Efficiency Curve 57

Figure 7-2: Power Derating Curve with Ambient Temperature (M15A_220) 58

Figure 7-3: Power Derating Curve with Ambient Temperature (M20A_220) 59

Figure 7-4: Power De-rating Curves with PV Voltage 60

Table

- Table 2-1: Packing list 13
- Table 2-2: Overview description 14
- Table 2-3: Rating label explanation 15
- Table 3-1: AC wires requirement 24
- Table 3-2: RS-485 Terminal block wiring 33
- Table 3-3: Bus Termination switch settings 34
- Table 3-4: Definition of digital input & EPO function 35
- Table 4-1: Inverter status 38
- Table 4-2: Inverter communication status 38
- Table 6-1A: Error Codes (Field Fault) and Messages 51
- Table 6-2A: Fault Codes (inverter fault) & Messages 52
- Table 6-2B: Fault Codes (inverter fault) & Messages 53
- Table 6-2C: Fault Codes (inverter fault) & Messages 54
- Table 6-3A: Warning Codes (Field warning) & Messages 54
- Table 6-4A: Warning Codes (inverter warning) & Messages 54
- Table 7-1A: Specifications 55
- Table 7-1B: Specifications 56
- Appendix-1: Assembly Note-1 61
- Appendix-2: Assembly Note-2 62

1 Safety

1.1 Information of the Inverter

1.1.1 Legal Provisions

Copyright – DELTA ELECTRONICS, INC. - All rights reserved.

This manual accompanies our product for use by the end users. The technical instructions and illustrations contained in this manual are to be treated as confidential and no part may be reproduced without the prior written permission of DELTA ELECTRONICS, INC. Service engineers and end users may not divulge the information contained herein or use this manual for purpose other than those strictly connected with correct use of the product. All information and specifications are subject to change without notice.

DELTA ELECTRONICS, INC. shall have no obligation to either personal injury and property damage claims hereinafter with respect to any actions -- (a) the product has been installed and/or repaired improperly; (b) the product has been misused without following the instructions on this user manual; (c) the product has failed due to incorrect unpacking.

1.1.2 Target Group

This manual of the solar inverter is prepared for the use by a well-trained technician for installing, commissioning, operation, and maintenance. The technician must have the following basic and advanced skills:

- Knowledge of the fundamentals of electricity, wiring, electrical components and electrical schematic symbols.
- Knowledge of how a solar inverter works and is operated.
- Training in the installation and commissioning of electrical devices and installations.
- Training in how to deal with the dangers and risks associated with installing and using electrical devices and installations.
- Compliance with this manual and all safety information.

1.2 General Safety

IMPORTANT SAFETY INSTRUCTIONS : SAVE THESE INSTRUCTIONS !



- Please read these instructions carefully and save them for later use.

To prevent personal injury and/or property damage, and also to ensure long term operation of the solar inverter, it is imperative this section be read carefully and all the safety instructions understood before using this inverter.

This user manual provides important instructions for DELTA grid-tie transformerless solar inverter. The product is designed, tested, verified, and certified according to international safety requirements, certifications, and standards but precautions must be observed when installing and operating the product.

This product is suitable for indoor and outdoor use.

ATTENTION : NO GALVANIC ISOLATION



- The inverter is not equipped with a transformer and has no galvanic isolation.
- Do not operate with grounding PV modules.
- It is prohibited to connect L1, L2, L3 and N terminal to ground.

1.2.1 Condition of Use

- The M15A_220 / M20A_220 is a transformerless solar inverter with 2 MPP tracking inputs, which converts the direct current from the PV array into grid-compliant three-phase current and feeds it into the utility grid.
- The photovoltaic modules used must be compatible with the inverter. PV modules with a high capacitance to ground must only be utilized if the coupling capacity does not exceed 5 μ F.
- The inverter must only be operated in countries for which it is approved by DELTA and the grid operator.

1.2.2 Symbols

This section describes the definition of the symbols in this manual. In order to prevent both personal injury and property damage, and to ensure long-term operation of the product, please read this section carefully and follow all the safety instructions while you use the product.

DANGER!



- This warning indicates an immediate hazard which will lead to death or serious injury.

WARNING !



- This warning indicates a possible hazard which may lead to death or serious injury.

CAUTION !



- This warning indicates a possible hazard which may lead to minor injury.

ATTENTION



- This warning indicates a condition of potential damage to property and/or the environment.

INFORMATION

- An exclamation mark enclosed in a double circle indicates additional important information is contained in the following section and the user should follow the instructions to prevent any hazards.

DANGER : ELECTRICAL HAZARD!!

- This warning indicates an immediate electrical hazard that unheeded can lead to death or serious injury.

CAUTION : HOT SURFACES, DO NOT TOUCH!

- This warning indicates a potential burn hazard.
- Use care when touching surfaces when operating the product.
- Do not perform any task until the product cools down sufficiently.



- This icon indicates that a prescribed time delay must elapse before engaging in an indicated action.
- Patientez le délai requis avant d'entreprendre l'action indiquée.



- This symbol indicates the location of an equipment grounding conductor (EGC) terminal.

2 Introduction

M15A_220 / M20A_220 is designed to enable the highest levels of efficiency and provide longest operating life of transformerless three-phase PV inverter by state-of-the-art high-frequency and low EMI technology. It is suitable for outdoor use.

ATTENTION : NO GALVANIC ISOLATION



- The inverter is not equipped with a transformer and has no galvanic isolation.
- Do not operate with grounding PV modules.
- It is prohibited to connect L1, L2, L3 and N terminal to ground.

2.1 Valid Model

The user manual is valid for the following device types:

- M15A_220
- M20A_220

This user manual must be followed during installation, operation, and maintenance.

DELTA reserves the right to make modifications to the content and technical data in this user manual without prior notice.

2.2 Product Overview

The components are shown as **Figure 2-1**.

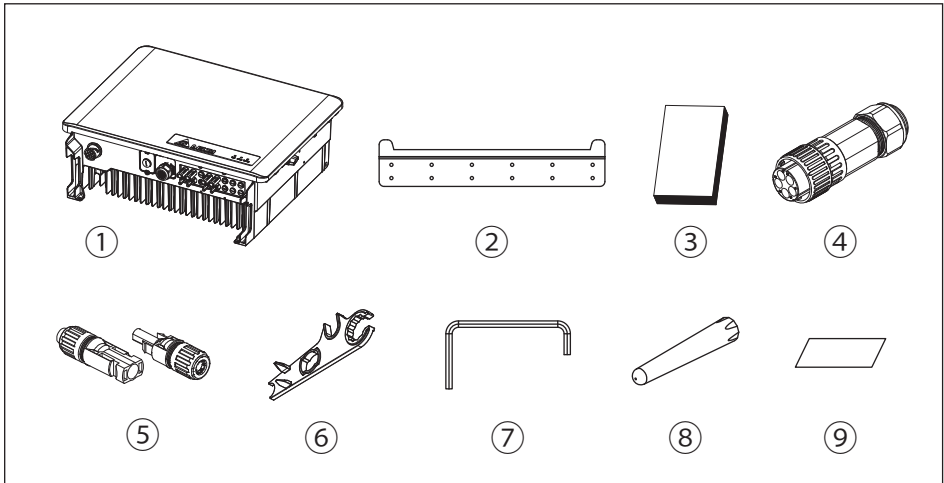

Figure 2-1: Components

Table 2-1: Packing list

M15A_220 / M20A_220			
	Object	Qty	Description
1	Delta Solar Inverter	1 pc	Solar inverter
2	Mounting Bracket	1 pc	Wall mounting bracket (Material: Aluminum/Thickness: 3mm)
3	User Manual	1 pc	Important instructions for solar inverter. Safety instructions should be followed during installation and maintenance.
4	AC Plug	1 set	Connector for AC connection
5	H4 Connector	4 pairs	DC String inputs
6	H4 Wrench	2 pcs	To disconnect H4 connector
7	Hexagon Driver (Installed on latch lock cover)	1 pc	To unscrew the latch lock cover and secure the door from closing.
8	Wi-Fi Antenna	1 pc	Antenna for Wi-Fi
9	Security Seal	6 pcs	Tamper stickers for M20A. (Taiwan use only)

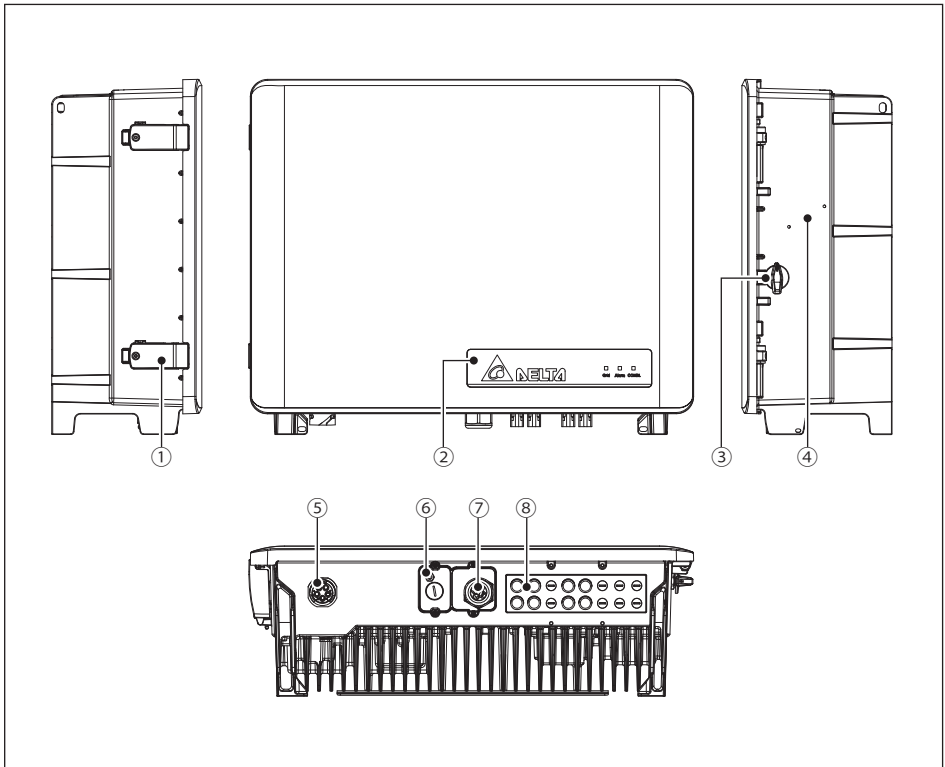

Figure 2-2: Overview

Table 2-2: Overview description

NO.	Component	NO.	Component	NO.	Component
1	Toggle Latch	2	LED	3	DC Switch
4	Reserved*	5	Gland for AC output	6	Wi-Fi Antenna port
7	Gland for RS-485	8	DC input (H4) x 4 strings		

*Always keep nut and screws properly tightened on the case. Water leakage may cause serious damage.

Figure 2-3 below, shows the certification and rating label.
Table 2-3 defines the symbol markings on this label.













<p>Model / 型號 M15A_220 Solar Inverter / 太陽能變流器 P/N: RPI153M220100</p> <p></p> <p>DC Input / 直流輸入 Max. Input Voltage / 最大輸入電壓 1000 Vd.c. MPP Voltage Range / MPP電壓範圍 380 ~ 900 Vd.c. Max. Input Current / 最大輸入電流 45 Ad.c. Max. Short Circuit Current / 最大短路電流 50 Ad.c. per MPPT</p> <p>AC Output / 交流輸出 Nominal Output Voltage / 額定工作電壓 400 / 380 Va.c. Nominal Output Frequency / 額定工作頻率 50 / 60 Hz Connection Type / 連接形式 3Ø3W / 3Ø4W, PE Max. Continuous Output Current / 最大輸出電流 25 Aa.c. Rated Continuous Output Power / 額定輸出功率 15000 W Rated Apparent Output Power / 額定視在功率 15000 VA Max. Apparent Output Power / 最大視在功率 16500 VA* Power Factor / 功率因數 0.8 lead ~ 0.8 lag *15000 VA max for AUNZ</p> <p>Protection Class / 保護等級 I Over Voltage Category / 過電壓類別 III (AC), II (DC) Ingress Protection / 防護等級 IP66 Operating Temperature Range / 操作溫度範圍 -25 ~ +60°C Non-isolated inverter 非隔離型變流器</p> <p>Authorized representative Delta Electronics (Netherlands) B.V. Zandvoort 15, 2132 MC Hooftdorp, The Netherlands</p> <p> AS 4777 2:2020 IEC 61439-2</p> <p> </p>	<p>Model / 型號 M20A_220 Solar Inverter / 太陽能變流器 P/N: RPI203M220100</p> <p></p> <p>DC Input / 直流輸入 Max. Input Voltage / 最大輸入電壓 1000 Vd.c. MPP Voltage Range / MPP電壓範圍 480 ~ 900 Vd.c. Max. Input Current / 最大輸入電流 48 Ad.c. Max. Short Circuit Current / 最大短路電流 50 Ad.c. per MPPT</p> <p>AC Output / 交流輸出 Nominal Output Voltage / 額定工作電壓 400 / 380 Va.c. Nominal Output Frequency / 額定工作頻率 50 / 60 Hz Connection Type / 連接形式 3Ø3W / 3Ø4W, PE Max. Continuous Output Current / 最大輸出電流 32 Aa.c. Rated Continuous Output Power / 額定輸出功率 20000 W Rated Apparent Output Power / 額定視在功率 20000 VA Max. Apparent Output Power / 最大視在功率 22000 VA* Power Factor / 功率因數 0.8 lead ~ 0.8 lag *20000 VA max for AUNZ</p> <p>Protection Class / 保護等級 I Over Voltage Category / 過電壓類別 III (AC), II (DC) Ingress Protection / 防護等級 IP66 Operating Temperature Range / 操作溫度範圍 -25 ~ +60°C Non-isolated inverter 非隔離型變流器</p> <p>Authorized representative Delta Electronics (Netherlands) B.V. Zandvoort 15, 2132 MC Hooftdorp, The Netherlands</p> <p> AS 4777 2:2020 IEC 61439-2</p> <p> </p>
-------------------------------------------------------------------------------------------------------------------------------------------------------------------------------------------------------------------------------------------------------------------------------------------------------------------------------------------------------------------------------------------------------------------------------------------------------------------------------------------------------------------------------------------------------------------------------------------------------------------------------------------------------------------------------------------------------------------------------------------------------------------------------------------------------------------------------------------------------------------------------------------------------------------------------------------------------------------------------------------------------------------------------------------------------------------------------------------------------------------------------------------------------------------------------------------------------------------------------------------------------------------------------------------------------------------------------------------------------------------------------------------------------------------------------------------------------------------------------------------------------------------------------------------------------------------------------------------------------------------------------------------------------------------------------------------------------------------------------------------------------------------------------------	-------------------------------------------------------------------------------------------------------------------------------------------------------------------------------------------------------------------------------------------------------------------------------------------------------------------------------------------------------------------------------------------------------------------------------------------------------------------------------------------------------------------------------------------------------------------------------------------------------------------------------------------------------------------------------------------------------------------------------------------------------------------------------------------------------------------------------------------------------------------------------------------------------------------------------------------------------------------------------------------------------------------------------------------------------------------------------------------------------------------------------------------------------------------------------------------------------------------------------------------------------------------------------------------------------------------------------------------------------------------------------------------------------------------------------------------------------------------------------------------------------------------------------------------------------------------------------------------------------------------------------------------------------------------------------------------------------------------------------------------------------------------------------------

Figure 2-3: Rating label

Table 2-3: Rating label explanation

Symbol	Definition
	Danger to life through electric shock Potentially fatal voltage is applied to the inverter during operation. This voltage persists even 60 seconds after disconnection of the power supply. Never open the inverter. The inverter contains no components that must be maintained or repaired by the operator/installer. Opening the housing will void the warranty.
	Beware of hot surface. This inverter can get hot during operation.
	This inverter is not separated from the grid with a transformer.
	The housing of the inverter must be grounded if this is required by local regulations.
	WEEE marking The inverter must not be disposed of as standard household waste, but in accordance with the applicable electronic waste disposal regulations of your country or region.

3 Installation

WARNING !



- Do not install the unit near or on flammable surfaces.
- Please mount the unit tightly on a solid / smooth surface.

CAUTION !



- High temperature may result in derated power output, the unit should not be installed in direct sunlight.
- Risk of injury when lifting the inverter or if it is dropped.

CAUTION !



The product supports wireless communication.

- Install the product as far away as possible from devices that emit strong radio waves, such as civil band radio equipment.
- Do not install the product in metal box and make sure there is no metal barrier between the product and connecting devices to prevent the communication signal attenuation.
- When using Wi-Fi to connect the inverter, the connection signal strength is recommended to be at least -70dBm to ensure good communication quality.

The chapter contains instructions for

- (1) Vertical wall mount
- (2) Electrical installation
- (3) Communication setup

3.1 Unboxing & Review

The unpacking procedure is shown as **Figure 3-1**.

The position of hook attachment for crane transporting is shown as **Figure 3-2**.

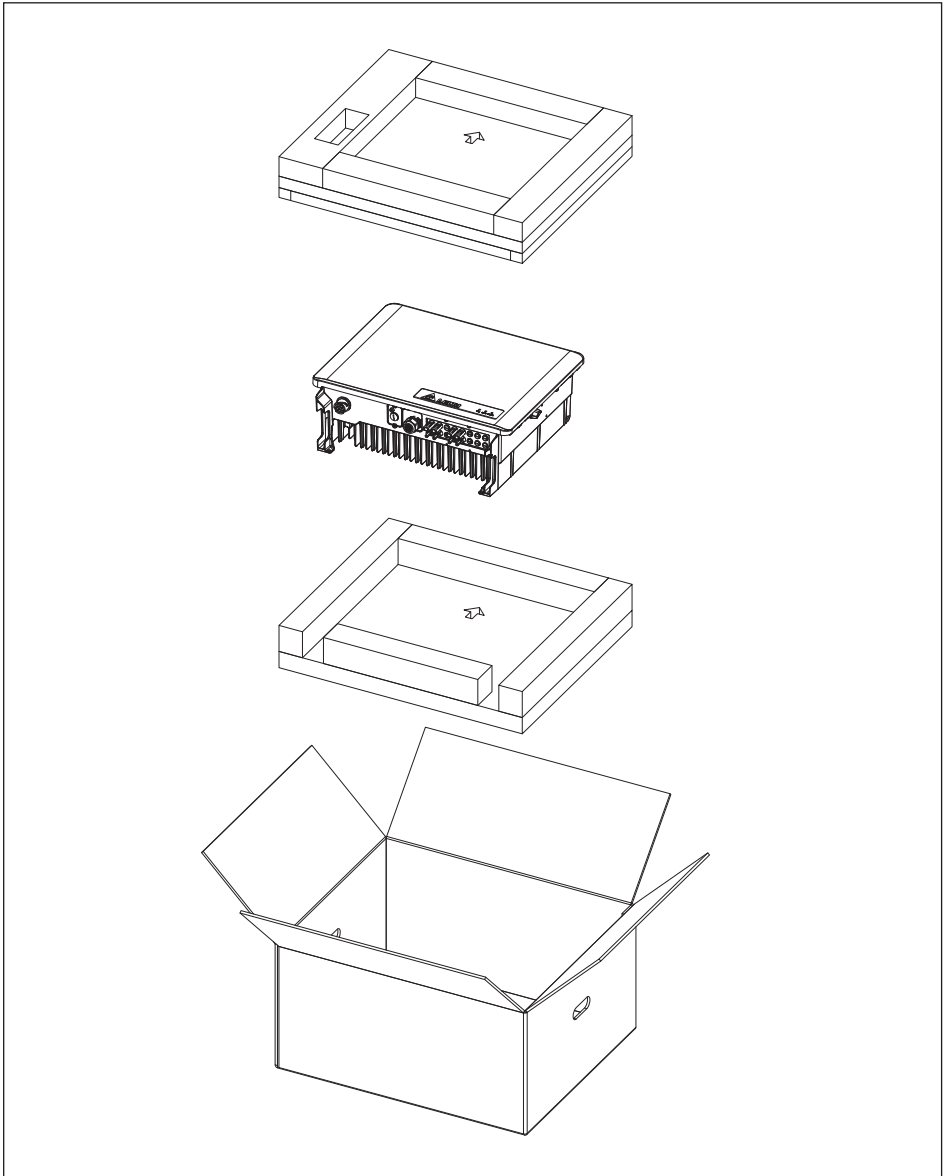

Figure 3-1: Steps to unpacke the inverter

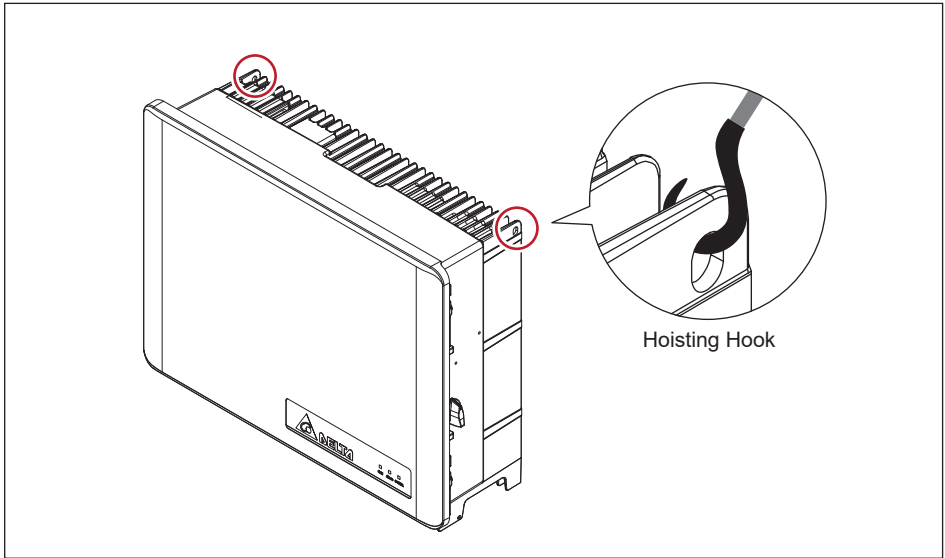

Figure 3-2: Attaching the Hoisting hooks

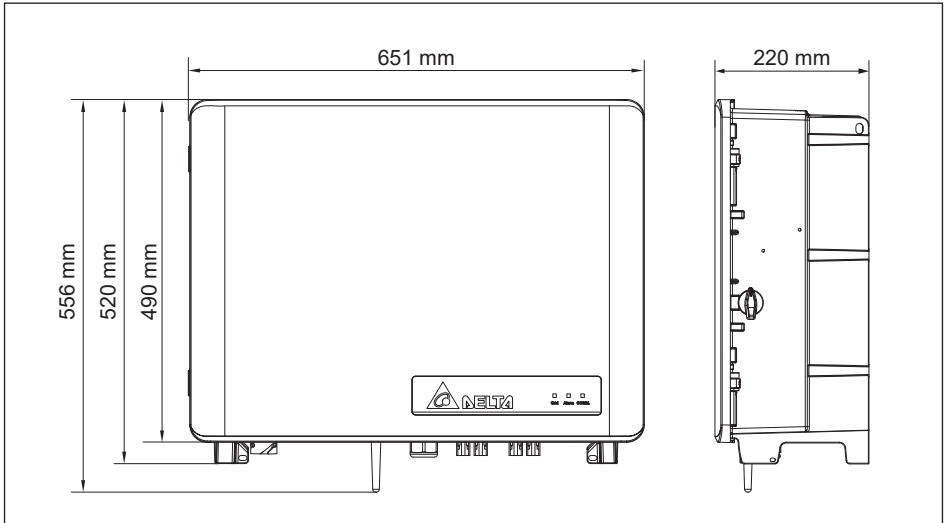

Figure 3-3: Inverter dimensions

3.2 Vertical wall mount

Refer to **Figures 3-4** to **Figure 3-7**.

1. Ensure the surface to which the unit is to be mounted is sufficiently strong enough to carry the weight of inverter.
2. Orient the wall bracket (**Figure 3-4**) horizontally (perpendicular to the floor).
3. Secure the mounting bracket on the wall with 12 M6 screws.
4. Hang the inverter on the wall mounting bracket.
5. Secure the inverter by 2 M5 screws on the position* shown as **Figure 3-5**.

* These are also grounding points for equipment grounding. (To ground the inverter, please refer to **Section 3.5**)

CAUTION !



- The mounting bracket provided with the unit is specially designed and is the only certified mounting device for mounting the inverter.
- Secure the mounting bracket on the wall with at least 6 M6 screws.
- Failure to comply with following mounting instructions including permitted orientations and designated clearances may result in derated power output and may void the warranty.

CAUTION !



To avoid malfunction of inverter caused by extreme weather (ex: snow, hail...etc) or non-proper installation/maintenance, an additional protection cover is strongly recommended to be installed by DELTA.
For more details, please contact local service team.

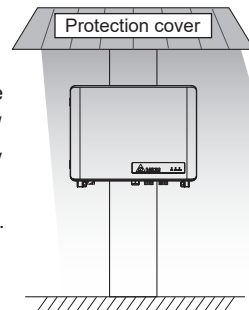

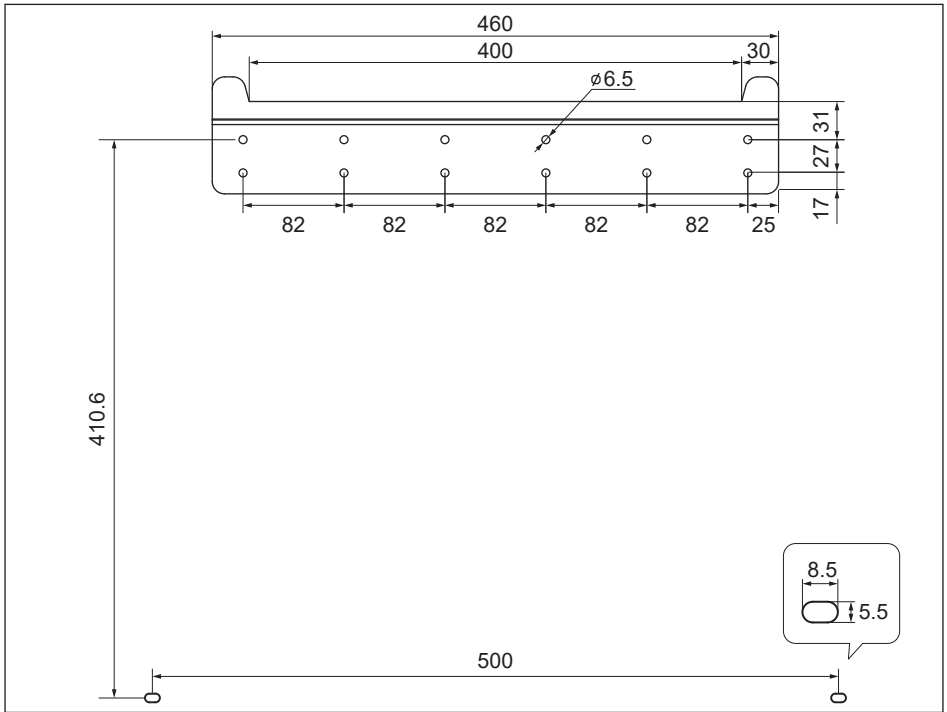

Figure 3-4: Mounting bracket dimensions

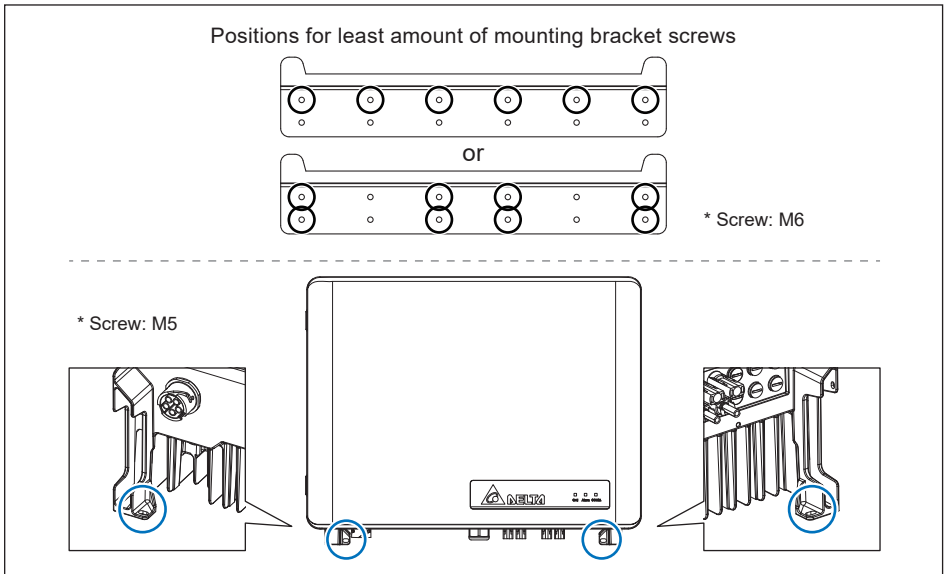

Figure 3-5: Positions of mounting screws

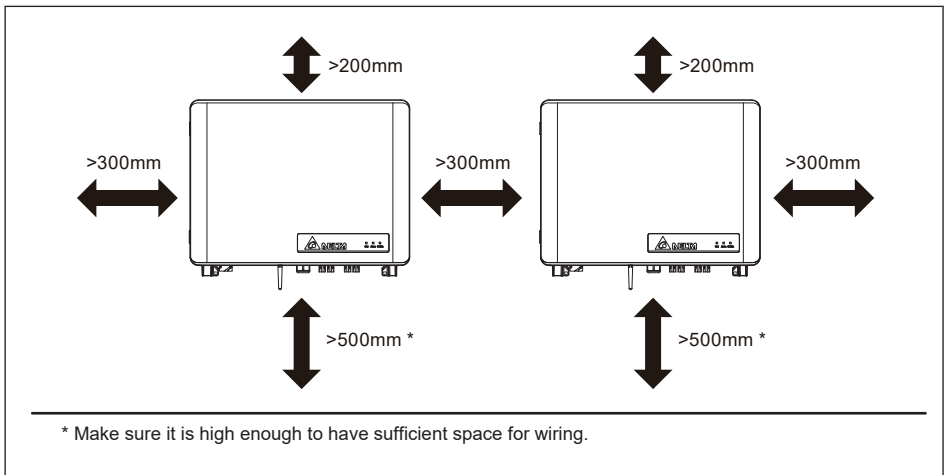

Figure 3-6: Separation distance of plural inverters

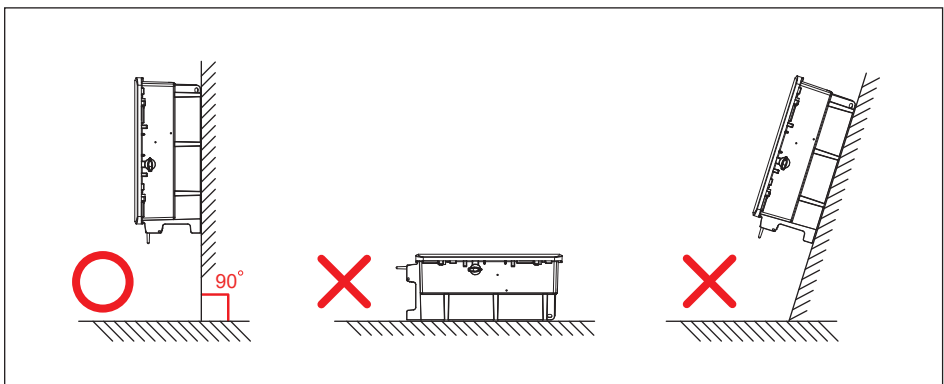

Figure 3-7: Permitted and prohibited mounting positions

3.3 Electrical Installation for AC Wiring

DANGER : ELECTRICAL HAZARD!!



- To avoid shock hazard during wiring, ensure any live grid connections are removed from the inverter.

WARNING !



- Code compliance is the installer's responsibility.

CAUTION : INVERTER AND EQUIPMENT DAMAGE MAY OCCUR !



- Installation for AC plug must meet the local electrical code.
- Failed to follow the instructions may damage AC cable.
- If there is any conflict between installation instruction and electrical code, please follow the electrical code.

ATTENTION



- The inverter may be damaged due to dust intrusion.
- Please do not open the lid of the inverter.

3.3.1 AC Grid Types and Connections

ATTENTION



The default AC Grid connection is 3Ø-4W. It can also connect 3Ø-3W without Neutral (N). The inverter will operate from the following grid connections without need of an external transformer:

TNC system

220/380V, 230/400V

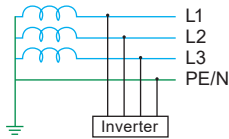

TNC-S system

220/380V, 230/400V

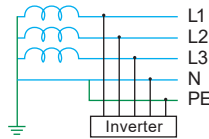

TNS system

220/380V, 230/400V

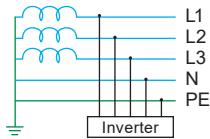

TT system

220/380V, 230/400V

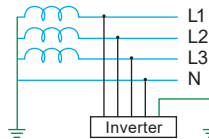

IT system

220/380V, 230/400V

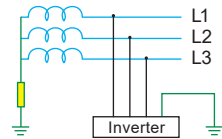

3.3.2 Required Protective Devices

It is recommended to install an upstream AC line disconnection and over current protection device. Please refer to your local rules for the required product.

The inverter integrates Residual Current Monitoring Unit (RCMU) for the detection of residual current and does not require an external residual-current protective device. However, if an external RCD is required by installation standard, a RDD/RCBO of type A or B with rating 300mA should be used.

3.3.3 Multiple Inverters in Parallel Connection

When multiple inverters are connected to the grid in parallel, the maximum number of inverters can be connected to a single winding of the transformer is 30.

3.3.4 AC Wiring Preparation

The AC wires must be jacketed and meet the specifications in **Table 3-1**.
 If there is any conflict with local electrical code, please follow the electrical code.

Table 3-1: AC wires requirement

Size of each wire	Cable diameter	Recommended Torque
8~14 mm ² (8~6 AWG)	20~26 mm	1.8~2.5 N·m

Follow the steps below to strip the wires before assembling the AC plug:

- Strip the outer jacket from the cable for 70mm.
- Strip 22 ± 2mm of insulation from all wires ends.

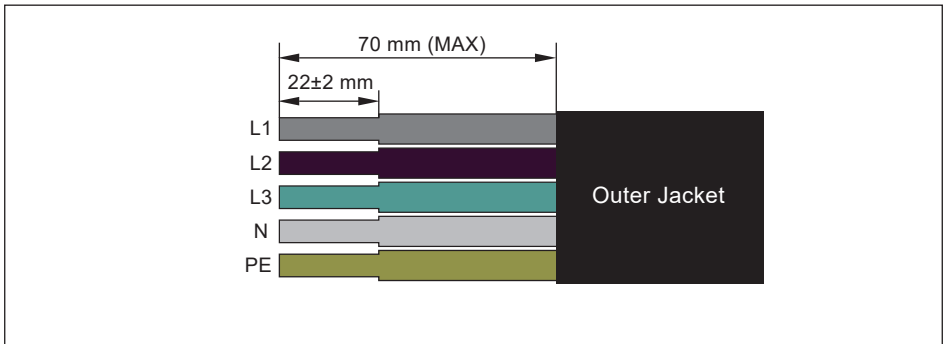

Figure 3-8 : Strip the wires

CAUTION ! Machine and equipment damage may occur.



- Make sure to choose proper size for AC cable.
- Failed to follow these instructions may cause AC plug damage.
- If there is any conflict between installation instruction and electrical code, please follow the electrical code.

3.3.5 AC Wiring

1. The packing has a AC Plug, please rotate it to release part A & B. **(Figure 3-9)**
2. Insert the cable into Part A (AC gland), and fix the internal wires (tighten by $\Phi 2.5\text{mm}$ wrench with $1.8\sim 2.5\text{ N}\cdot\text{m}$ torque) into Part B. **(Figure 3-11)**
3. Rotate part A & B as **Figure 3-12** to fit and fix it onto the inverter.

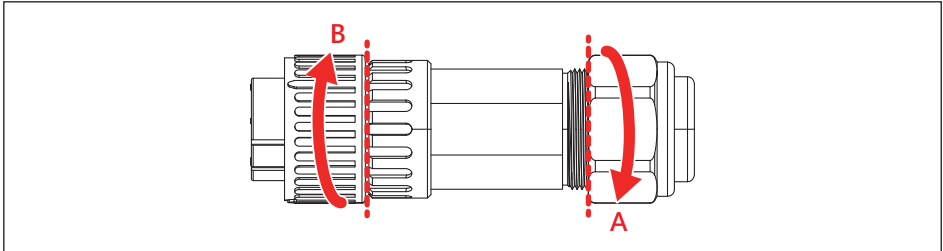

Figure 3-9 : Assemble the AC plug

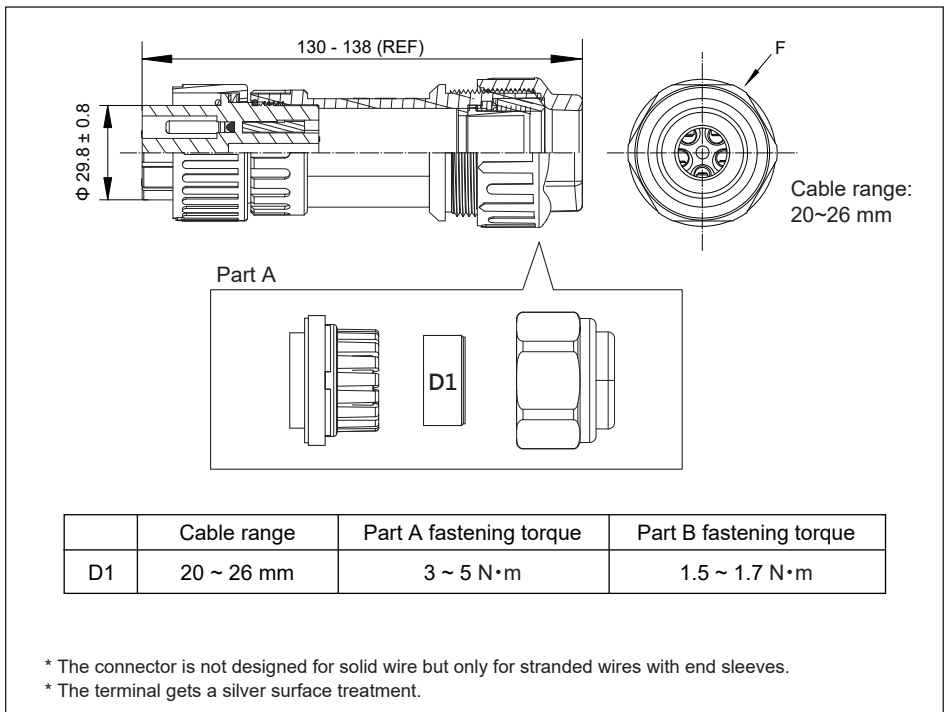

Figure 3-10 : The rubber rings of AC gland

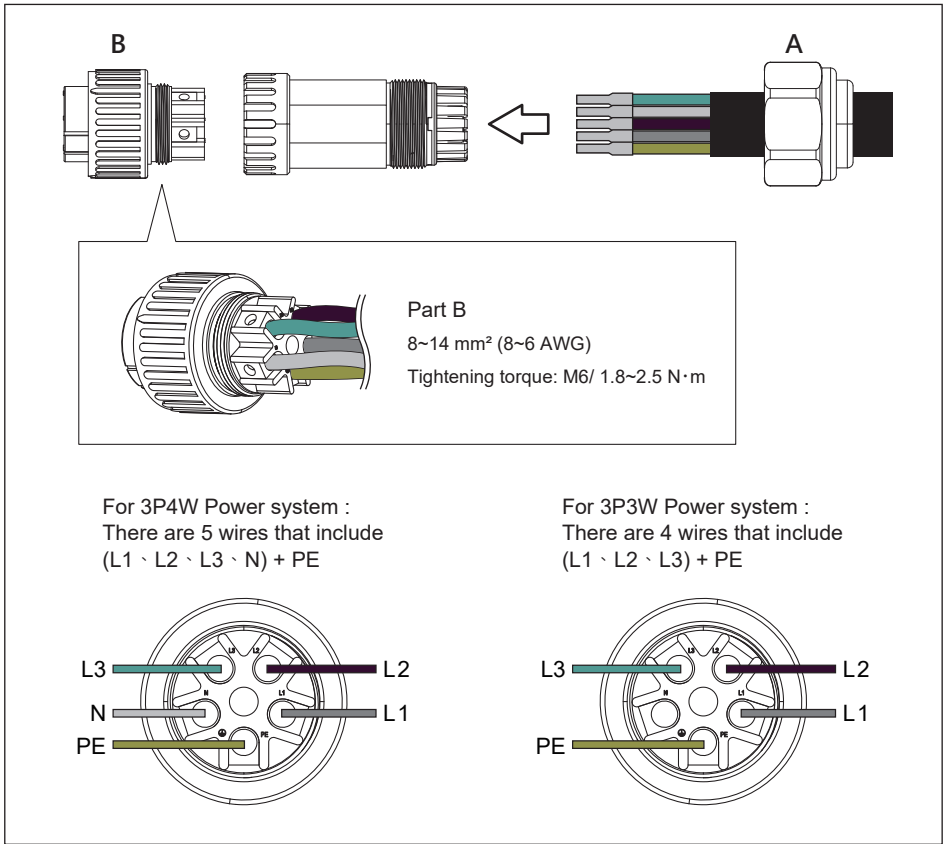

Figure 3-11 : AC wiring

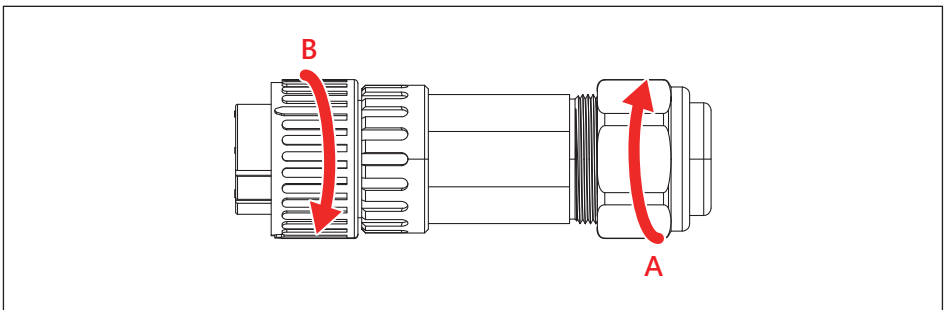

Figure 3-12 : Rotate the AC plug to fit

3.4 Electrical Installation for DC Wiring

DANGER : ELECTRICAL HAZARD!!



- PV arrays convert sunlight into electric power with high DC voltage and high DC current which can cause dangerous electrical shock!
- Use opaque material to cover the PV arrays before wiring or cabling.
- Ensure the correct polarities are connected when DC cabling is applied.
- The amount of PV module of each string within one MPPT should be the same to avoid the circulating current between the strings.

WARNING !



- The inverter may overheat and catch fire under fault conditions.
- Only PV modules that are listed with system voltage under 1100V are permitted for use.
- Make sure the DC switch is in the "OFF" position, and disconnect the PV array before plug in/out the DC connectors.
- Inverter warranty void if the DC input voltage exceeds 1100 Vdc.

ATTENTION

- The PV Array current carrying conductors (positive or negative) must not be referenced to ground.
- Before plug in the DC connectors, please notice the polar of connectors. Reverse positive and negative voltage will make damage.

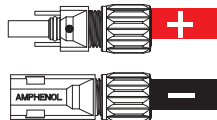

- Do not remove the waterproof plug for unused DC strings.

Please read the following instructions for connecting DC connector :

- Ensure the DC conductors used are Cu and sized to the correct ampacity per NEC or other local code
- Strip off all wires for 6.5~7.5 mm.
- The cross-sectional area for each DC conductor is 12~10 AWG (4~6 mm²).
- Choose the DC string wire size based on NEC requirements or other local code.

M15A_220 / M20A_220 uses H4 type connectors mounted on the bulkhead to connect the string to the inverter.

Mating connectors (See **Figure 3-13**) are provided within the packing.

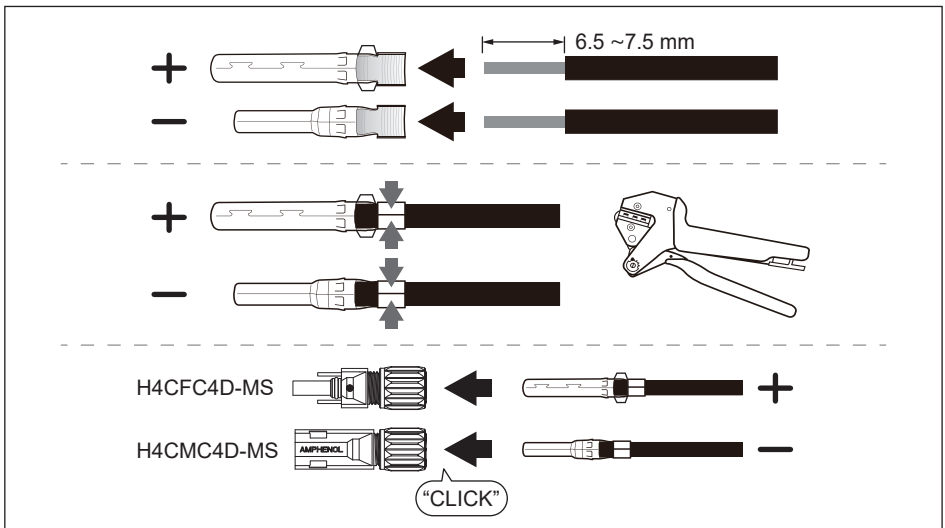

Figure 3-13: DC wiring illustration

The polarities of DC wiring are divided into positive and negative, layout of the connectors is shown as **Figure 3-14**.

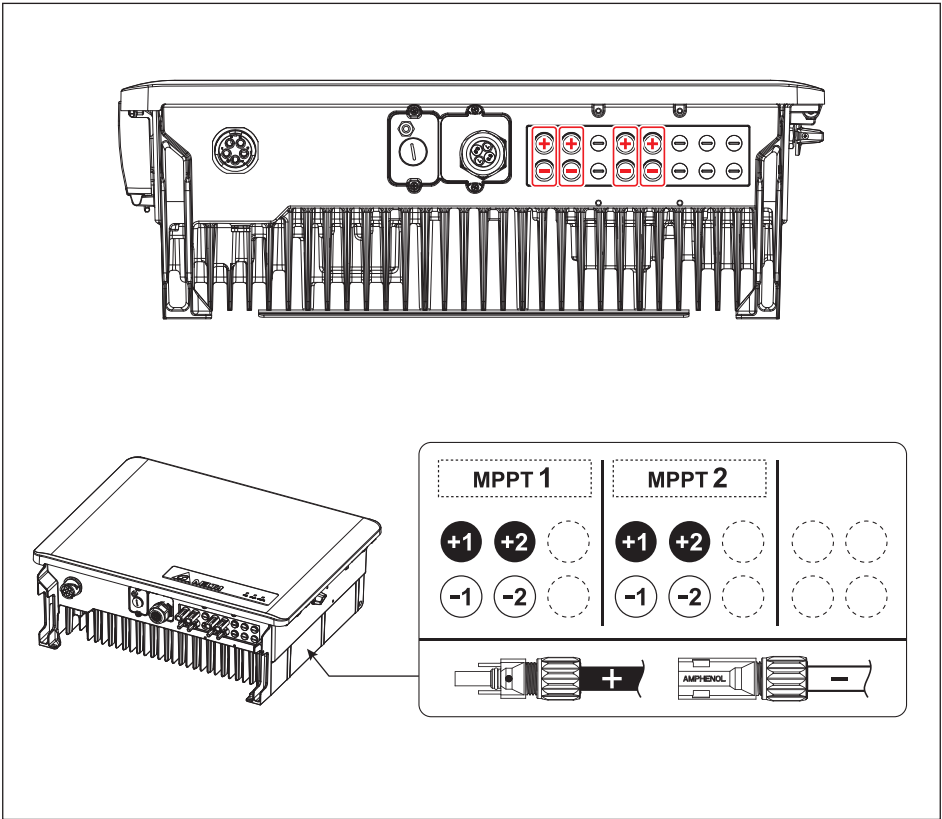
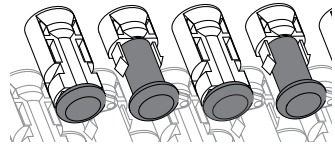

Figure 3-14: Location of H4 connectors to connect array wiring (DC)

ATTENTION



- For unused DC connectors, please keep the cap on to prevent water or dirt intrusion.



3.5 Equipment Grounding

To ground the inverter, please crimp the grounding wire to ring terminal lug and fix it on the grounding point shown as **Figure 3-15**.

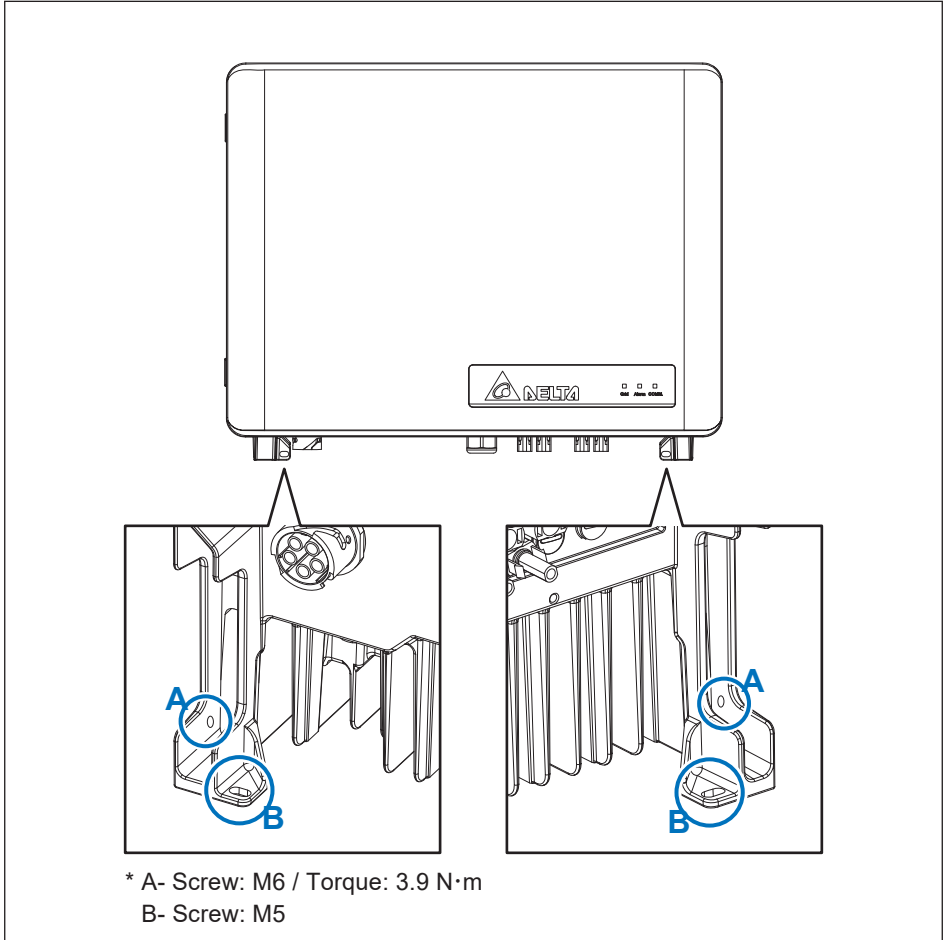

Figure 3-15: Mount the equipment grounding

3.6 Communication Module Connections

The communication module of M15A_220 / M20A_220 is shown in **Figure 3-16**. It provides VCC(12V), RS-485, dry contact, EPO, and digital input terminals for various applications, and it can be extended to ability to use Sub_1G.

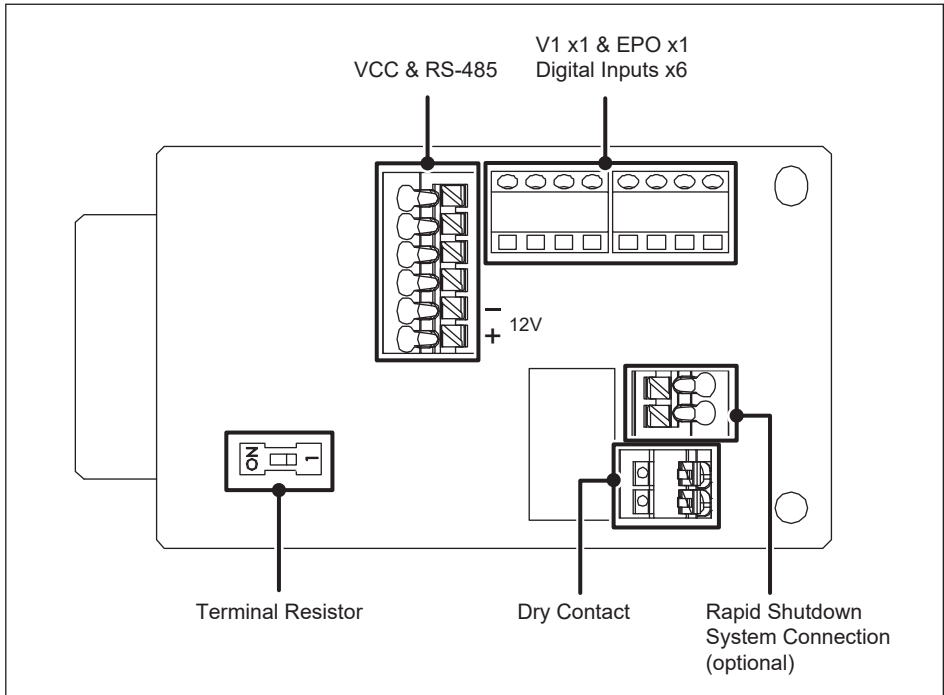

Figure 3-16: Communication module layout

3.6.1 Accessing the Communication Module

The communication module consists of an assembly with a PCB and a plastic carrier. It is located in slot through the bottom of the chassis.

It can be accessed from the chassis bottom outside. The carrier is fixed to the chassis by two self-retaining screws. See **Figure 3-17**.

Loose the self-retaining screws from the chassis, and gently pull the carrier straight out of the chassis to withdraw the communication module.

After passing the required signal cable through the wiring gland provided or a connected conduit and making the electrical connections as shown in the following sections, the module can be reinstalled in the opposite direction described above.

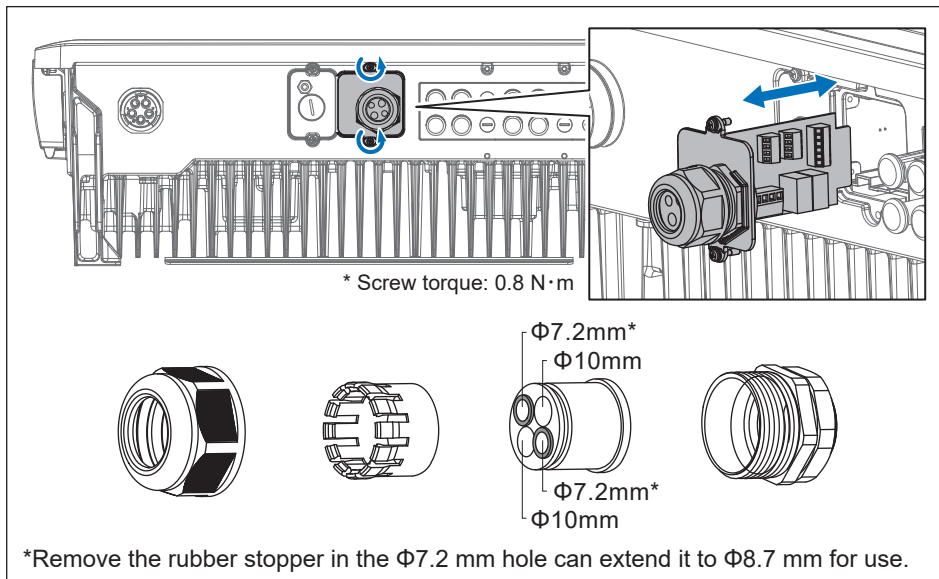
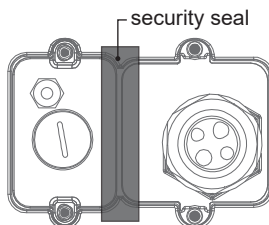

Figure 3-17: Location and access to communication module

ATTENTION



This inverter is compliant with the “Technical Specification for Security Inspection of Solar Inverter and Monitoring Units” required by BSMI. After completing the communication wiring, please apply a brand new one-time-use security seal (item 9, **Table2-1**) on the carrier. We will not be liable or responsible for any security incident caused by an improper application of the sticker.



3.6.2 RS-485 Connection

The pin definition for the RS-485 terminal block is shown in **Table 3-2**.

- Pins 1 and 2 provide a 12VDC bus for use with accessories.

(If use of the 12VDC bus is necessary, please set switch 1 to the ON position.)

- Pins 3 and 5 are both connected to the DATA+ input.

- Pins 4 and 6 are both connected to the DATA- input.

These connections allow easy daisy-chaining of multiple inverters.

A 120ohm bus termination resistor and associated control switch are located on the communication board. The switch function is as shown in **Table 3-3**.

Different RS-485 connection scenarios require different set up for the 120ohm bus termination resistor.

- When multiple inverters are cascaded (i.e., "daisy-chained"), only the last inverter in the chain must have its bus termination resistor switched ON. (**Figure 3-18**)
- If the length of any RS-485 bus is greater than 610m, it is recommended to use Belden 3105A cable (or equivalent cable) to ensure communication quality.

ATTENTION



- It is recommended to use twisted-pair as a communication cable for well transmission quality.

Table 3-2: RS-485 Terminal block wiring

Pin	Function
1	VCC (+12V)
2	GND (It is NOT the PE)
3	DATA+
4	DATA-
5	DATA+
6	DATA-

INFORMATION



When the RS-485 cable needs to be grounded, please follow the steps below.

1. strip a wire from the shielding layer and properly insulate it
2. crimp the insulated wire to the Y-type lug and fix it in position A

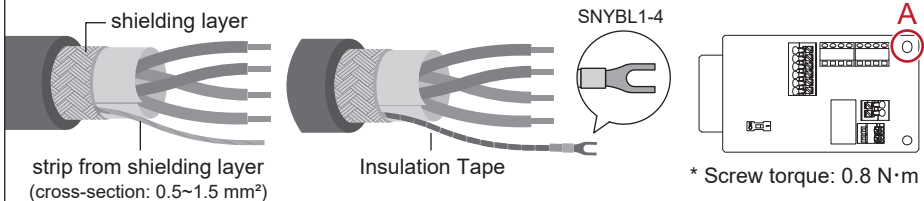

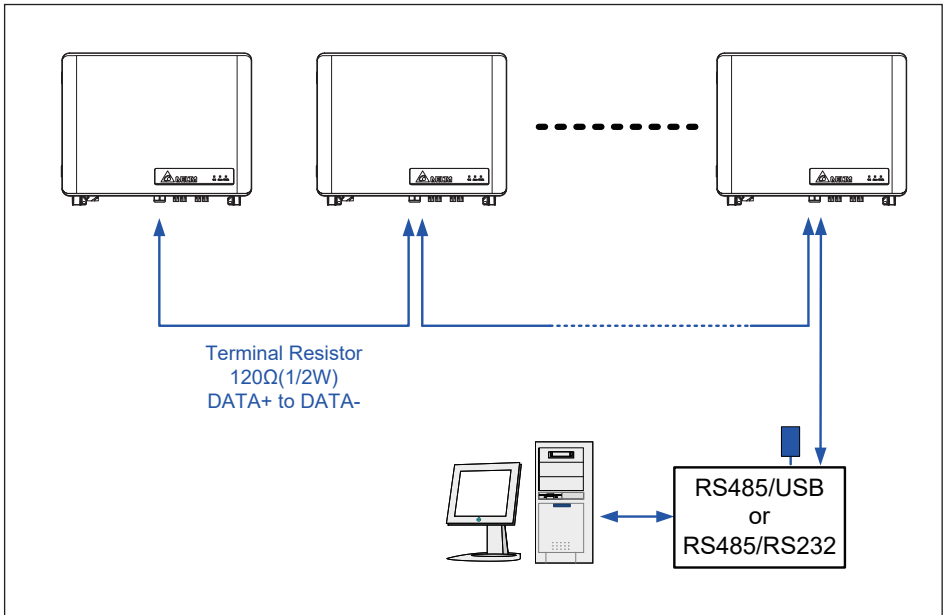

Figure 3-18: Multiinverter connection illustration



Table 3-3: Bus Termination switch settings

	Switch 1
ON	Terminal Resistor ON
1	Terminal Resistor OFF

3.6.3 EPO Function & Digital Input

The communication Module has an emergency power off function (EPO). Users can customize EPO function in APP or Delta Solar System (DSS).

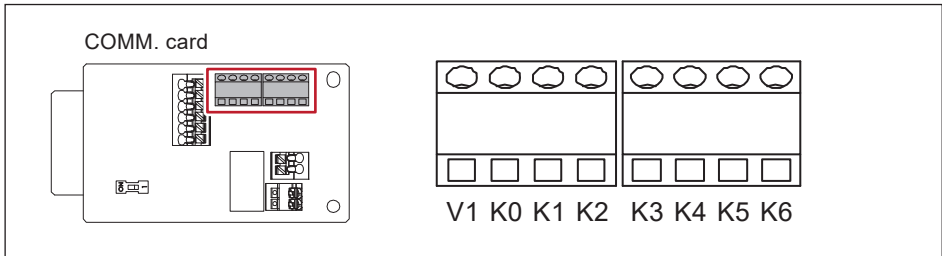

Figure 3-20: EPO and digital input function terminal block

Once enabled, the EPO function can be used to turn off the inverter through the relayless contacts connected to terminals [V1 & K0].

A digital power reduction control function is provided, which can be set to limit the available active output power of the inverter. The control settings for this function are made by placing a hardware short circuit (jumper or relay) between the two terminals of the terminal block shown in **Table 3-4**.

For Australia and Newzealand, please refer to **Table 3-5**.

Table 3-4: Definition of digital input & EPO function

Short terminals	Inverter's action
V1 & K0	Emergency power off (EPO)
V1 & K1	0% active power
V1 & K2	Maximum 30% rated power
V1 & K3	Maximum 60% rated power
V1 & K4	Maximum 100% rated power
V1 & K5	Reserved
V1 & K6	Reserved

Table 3-5: Definition of DRMs for Australia and New Zealand

Short	Inverter's action
V1 & K1	DRM5 (0% active power)
V1 & K2	DRM6 (Maximum 50% active power)
V1 & K3	DRM7 (Maximum 75% active power and sink reactive power)
V1 & K4	DRM8 (Maximum 100% active power and sink reactive power)
V1 & EPO	DRM0 (Emergency power off)

3.6.4 Dry Contact Connection

M15A_220 / M20A_220 provides 1 set of dry contacts, which can be used to control external devices according to the operating status of the inverter.

The terminal block for this function is shown in **Figure 3-20**. The terminals marked in the figure identify the dry contact connection.

The dry contacts operation are usually open. User can customize the function of this contact through the APP or DSS.

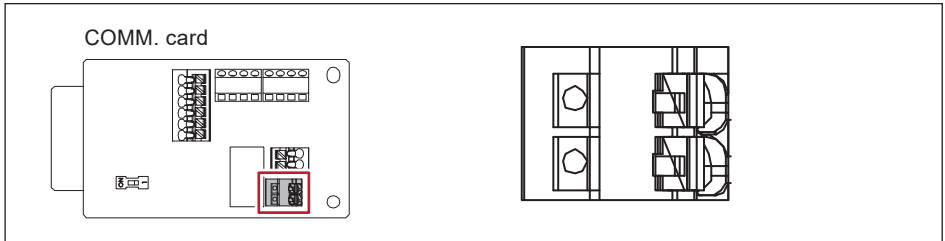

Figure 3-20: Dry Contact connection

3.6.5 Rapid shutdown system connection (optional)

M15A_220 / M20A_220 provides a terminal to control the rapid shutdown system. This terminal provides a 12 VDC, Max.1 A power in normal condition, but the power will turn-off in 2 seconds when the AC grid outage.

The terminal block for this function is shown in **Figure 3-21**.

1. 22~12 AWG solid or stranded wire is available for the terminal hole and wire length is limited to 10 M.
2. Stripping length is 6 ~ 7 mm.

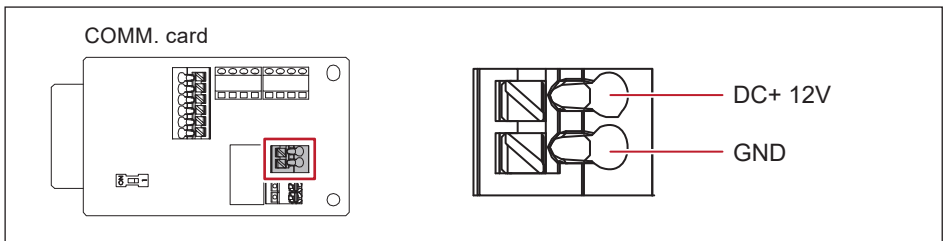

Figure 3-21: Rapid Shutdown System connection

3.7 Wi-Fi

The communication module supports the inverter to communicate with devices (such as smartphones, tablets, etc.) via Wi-Fi (base WPA2-PSK).

User can restart the function through the APP or DSS.

There is an antenna for Wi-Fi in the package (item 8, **Table 2-1**), which must be mounted on the plastic carrier as the procedure below.

1. Remove the protective nut.
2. Tighten the antenna.

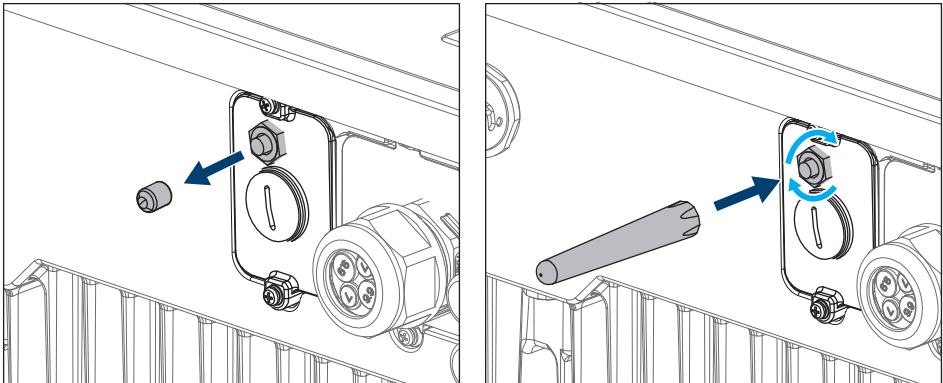
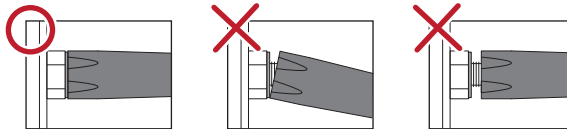

Figure 3-22: Installation of Wi-Fi antenna

ATTENTION

- Please properly install the antenna as shown below to keep communication quality and avoid equipment damage.



- More detail for Wi-Fi connection and APP :
<https://mydeltasolar.deltaww.com/index.php?p=manual>



- To establish a successful communication between Inverter Wi-Fi to MyDeltaSolar Cloud, in the Wi-Fi connection setup page, the signal strength must be above -70dBm between each Wi-Fi device (Wi-Fi router, inverter, DC1...etc.). In case the signal strength is below -70dbm, it may cause certain communication errors which may prevent a successful Wi-Fi communication. To avoid such issues, please adjust the Wi-Fi device position to improve the signal strength/quality.

4 Commissioning

CAUTION : HOT SURFACES, DO NOT TOUCH!



- Use care to avoid hot surfaces when operating the product!
- Do not perform any task until the unit cools down or wear appropriate personal protective equipment.

4.1 LED Signals

M15A_220 / M20A_220 with 3 LEDs can visually display the status of the inverter, as shown in **Figure 4-1**.

Table 4-1, 4-2 provide the information of LED indicators.

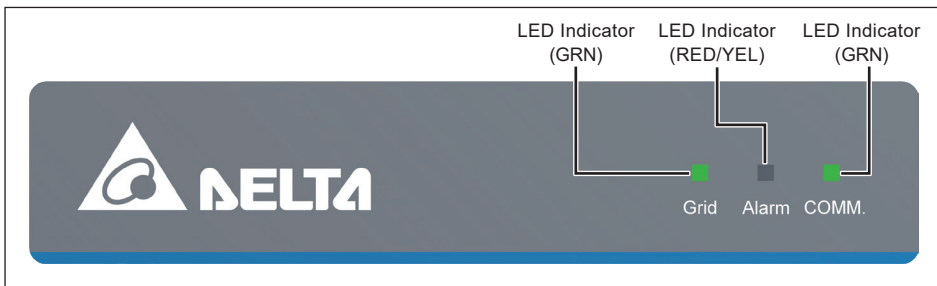

Figure 4-1: LED indicators

Table 4-1: Inverter status

Condition	Grid (Green)	Alarm (Red/Yellow)
Countdown	FLASH	OFF / OFF
On Grid	ON	OFF / OFF
Inverter Fault / Remote off	OFF	ON / OFF
Inverter Warning	ON (or OFF)	FLASH / OFF
Field Fault	OFF	OFF / ON
Field Warning	ON	OFF / FLASH
NO DC	OFF	OFF / FLASH SLOW
FW Upgrade	FLASH	FLASH / OFF
Standby	FLASH	OFF / FLASH
Check PV Power	FLASH FAST	OFF / FLASH FAST
System Lock	OFF	FLASH / FLASH

*FLASH: ON 1s / OFF 1s

FLASH FAST: ON 0.25s / OFF 0.25s

FLASH SLOW: ON 5s / OFF 10s

Table 4-2: Wireless communication status

Connection Status	COMM. (Green)
Offline	OFF
Wi-Fi	FLASH (ON 1s / OFF 2s)

4.2 Auto ID Commission

The Auto ID function can set all inverter IDs at once by DSS (Delta Solar System) or DeltaSolar APP.

- DSS

Connect the inverter through RS-485 or Wi-Fi with computer.

- APP

Connect the inverter through Wi-Fi with mobile device.

(please refer to **chapter 4.3** for operation manual.)

4.2.1 Commission Setting (DSS)

- ① Select the corresponding model
- ② Select RS485 or Wi-Fi to connect the computer and inverter
- ③ If use RS485, select communication port (automatic detection by the system)
- ④ Click 

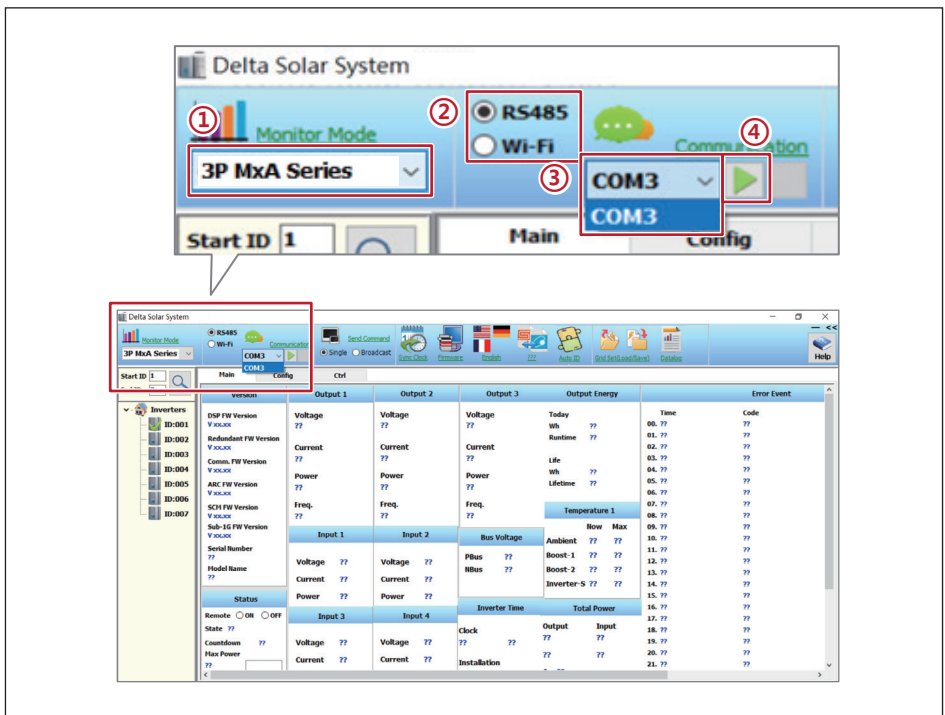



Figure 4-2: DSS Commission setting

4.2.2 Scan inverter

- ① Click “Auto ID” 
- ② Enter numbers of inverters.
- ③ Click “Scan”.

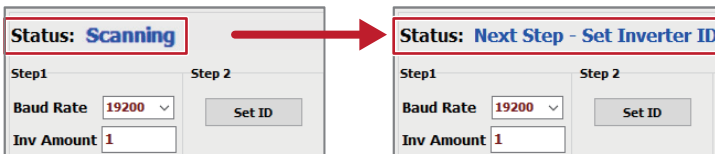
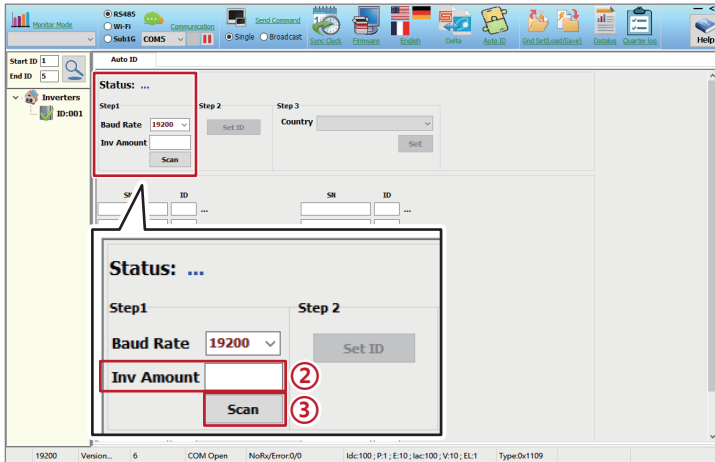

Figure 4-3: Steps of scanning inverters

4.2.3 Set ID

- ① The serial number of the successfully scanned device will be displayed below, the default ID can be changed.
- ② After ID setting is completed, click “Set ID”.

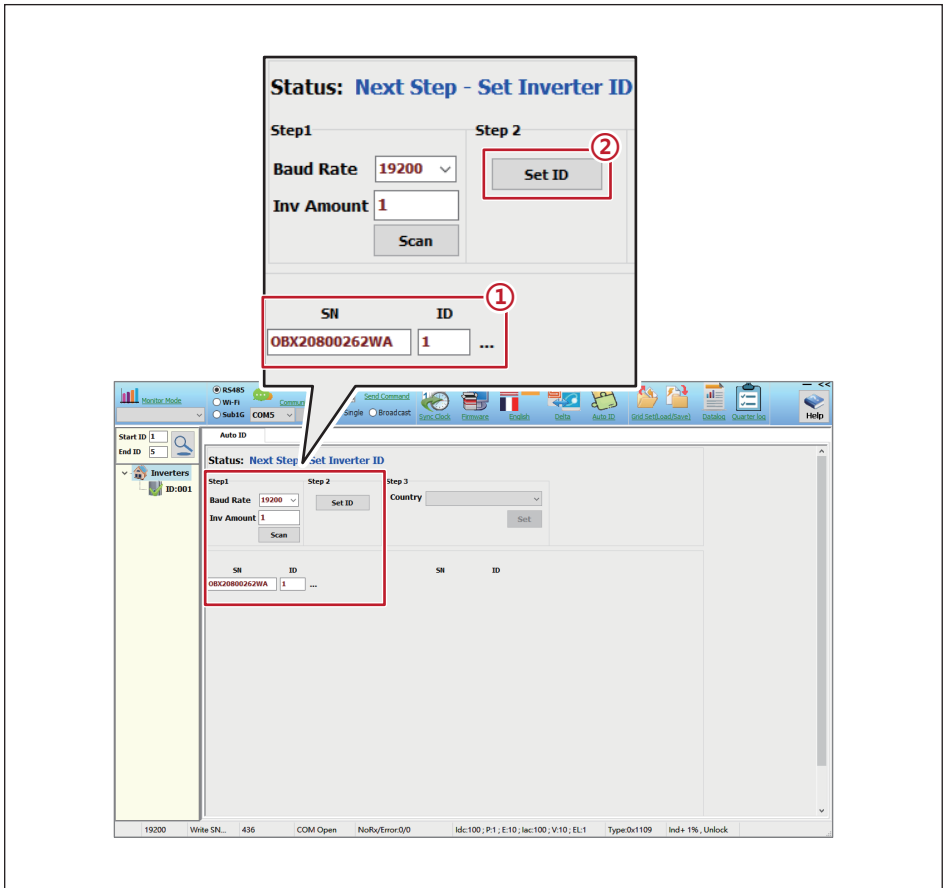

Figure 4-4: Steps of ID setting

4.2.4 Set Country

- ① Click to select the country of inverter.
- (For compliance with AS/NZS 4777.2:2020, please select from Region Australia A/B/C and NZ.)
- ② Click “Set”.

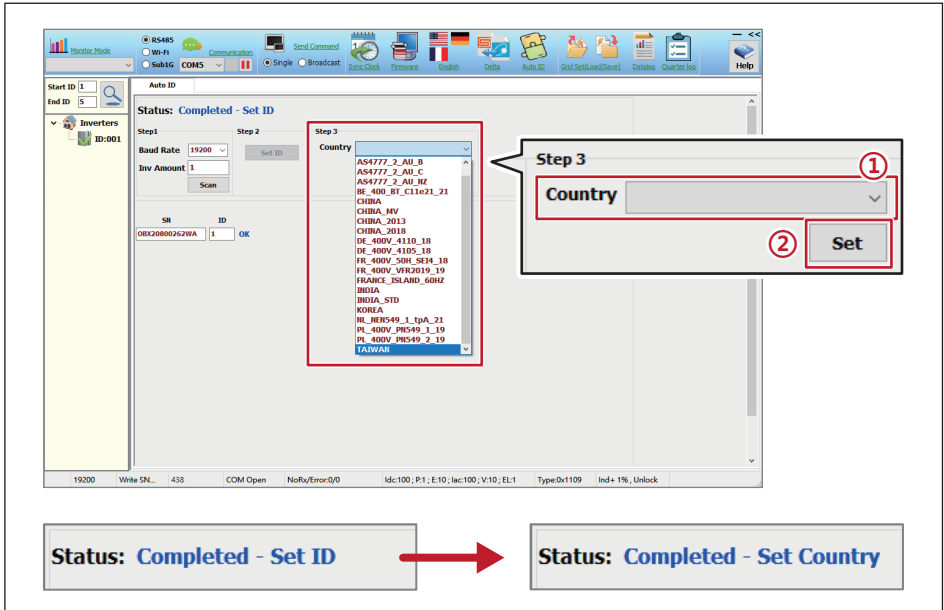

Figure 4-5: Steps of country setting

4.2.5 Synchronize time

Click “Sync Clock  ” to Synchronize time.

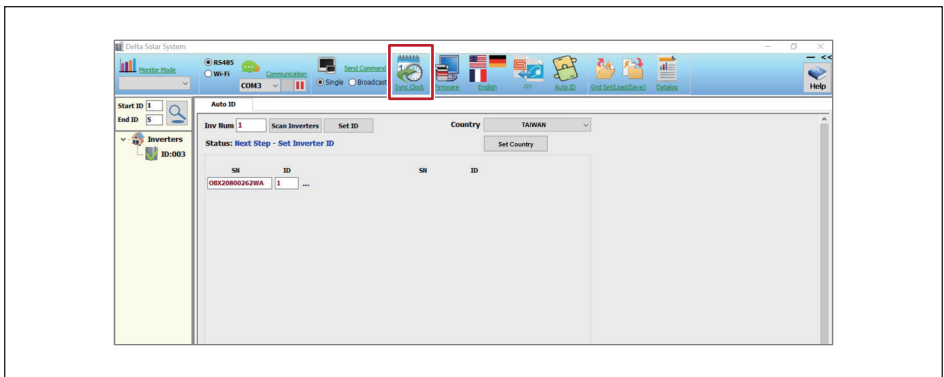

Figure 4-6: Steps of time synchronization

4.3 Delta Function Setting

Delta offers two setting tools:

DSS (Delta Solar System Software) and APP (DeltaSolar)

Function	
Active power control	Q(U) control (volt-var control)
P-F control (watt-frequecy control)	Q by night(Q setting 24/7)
P(U) control (volt-watt control)	Anti-PID
Fixed cosφ	Dry contact
Fixed Q(%)	ARC fault detection
Auto ID	Wi-fi

Please refer to the following link for operation manual.

DSS Operation Manual:



https://mydeltasolar.deltaww.com/manual/eng/SUB_1G/DSS.pdf

DeltaSolar (APP) Operation and Installation Manual:



<https://mydeltasolar.deltaww.com/index.php?p=manual>

5 Maintenance

Regular maintenance can ensure that the inverter maintains great performance. DELTA recommends that the unit should be inspected at least every 6 months. The maintenance frequency should be adjustable, depending on the sit environment, different seasons and weather effects.

DANGER : ELECTRICAL HAZARD!!



- Make sure that both AC breaker and DC switch are turned off and the LED indicators are off to avoid the risk of electric shock!

5.1 Open and Close the Door

In order to ensure the normal long-term operation of the inverter, the door must be opened and closed according to the following step.

5.1.1 Open Door

WARNING !



- Do not attempt to open the door under raining condition.
- Before opening the front door, please wipe the inverter case if it is wet to avoid water seepage.

1. Loosen the screws on both latch covers with hexagon wrench attached on the latch cover. (**Figure 5-1**)
2. Open the latch covers and release latches to open the door. (**Figure 5-1**)
3. Use the hexagon wrench to secure the door from closing. (**Figure 5-2**)

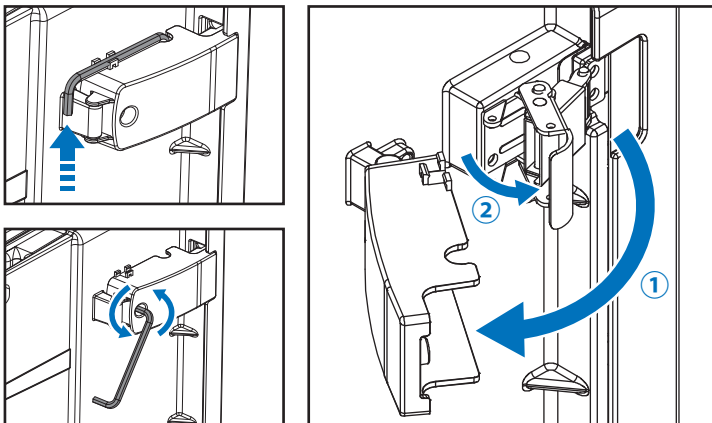

Figure 5-1: Open and close the door

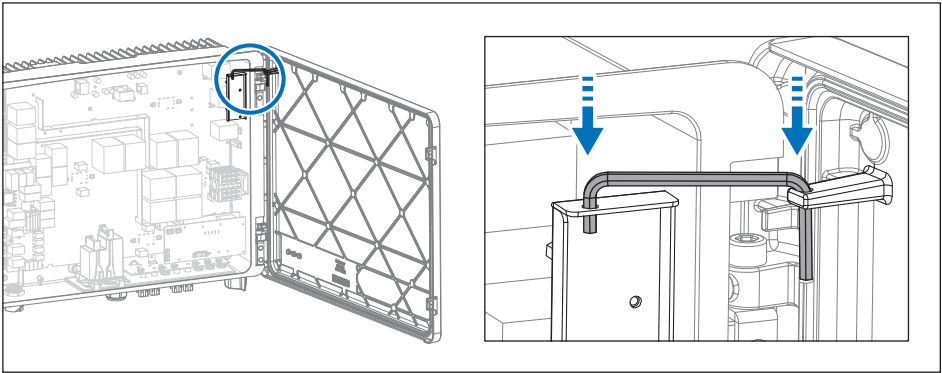

Figure 5-2: To secure door by hexagon driver

5.1.2 Close Door

ATTENTION



- Due to corrosion of live parts, excessive moisture or dust in the inverter may cause accidental damage. Ensuring that the inner of the inverter is clean free from unreasonable pollution is important for long service operating systems.
- After cabling or maintenance for the inverter, please lock both toggle latch to make sure the inverter will remain IP66 protection.

1. Ensure that the gasket in the mounting slot and mating surface on the enclosure are clean and in good condition.
2. Make sure all protective covers are properly installed.
3. Remove the hexagon wrench and close the door.
4. Buckle the latch and apply a one-time-use security seal (item 9, **Table 2-1**) on the top toggle latch as the following attention.
5. Secure the latch cover with the hexagon wrench.
6. The hexagon wrench can be fixed on the latch cover.

ATTENTION



- This inverter is compliant with the “Technical Specification for Security Inspection of Solar Inverter and Monitoring Units” required by BSMI. After closing the door, please apply a security seal on the toggle latch. We will not be liable or responsible for any security incident caused by an improper application of the sticker.

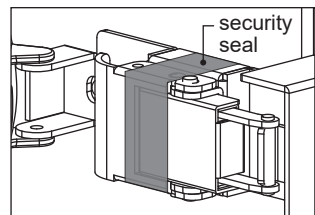

5.2 Replacement of Surge Protection Devices (SPD)

Locations of Surge Protection Devices (SPD) for AC and DC wiring are shown below. The SPD should be replaced if damaged.

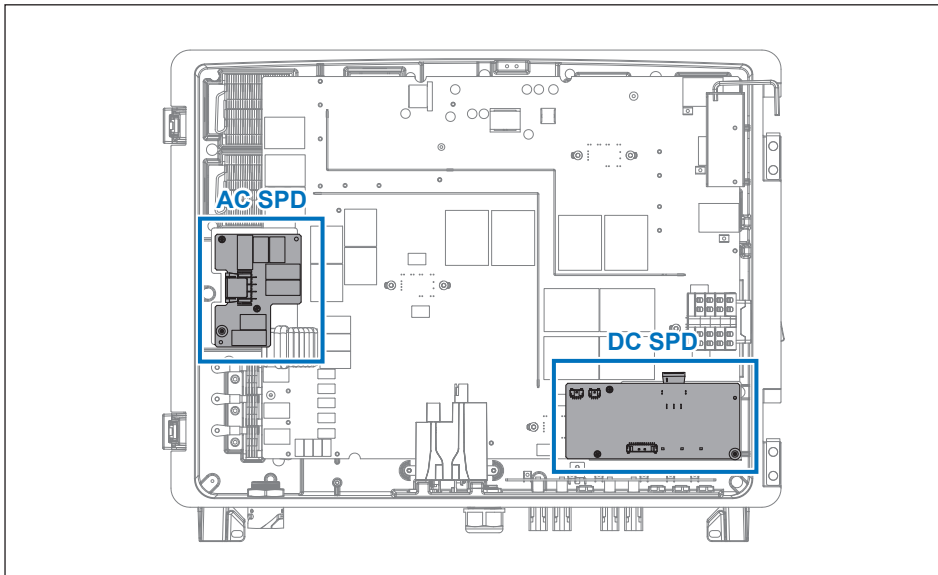

Figure 5-3: Location of AC and DC SPD board

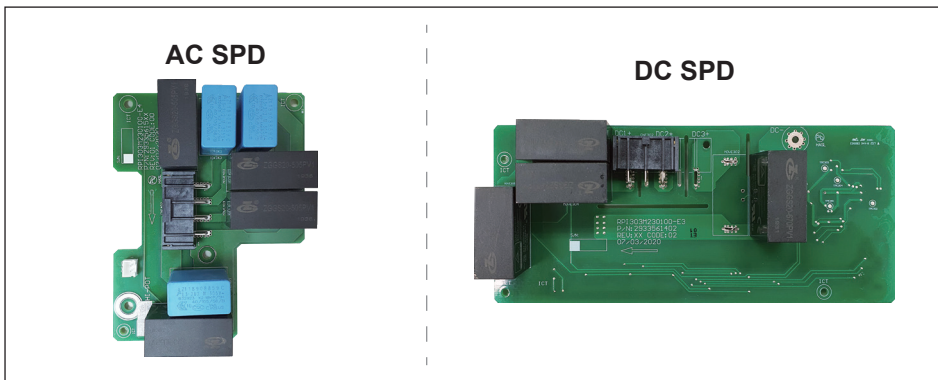

Figure 5-4: AC and DC SPD module

If the warning message “AC Surge” or “DC Surge” appears on the APP and DSS, please follow the steps below to replace the SPD.

5.2.1 Replace AC SPD

1. Turn off the AC and DC power, and wait until the LED indicators turns off.
2. Follow **Section 5.1.1** to open the door.
3. Loosen 3 screws, remove wires and disconnect signal cable to take off AC SPD.
4. Install the new AC SPD unit with procedures above in reverse order and tighten the screw with 0.8 N·m torque.
5. Follow **Section 5.1.2** to close the door.

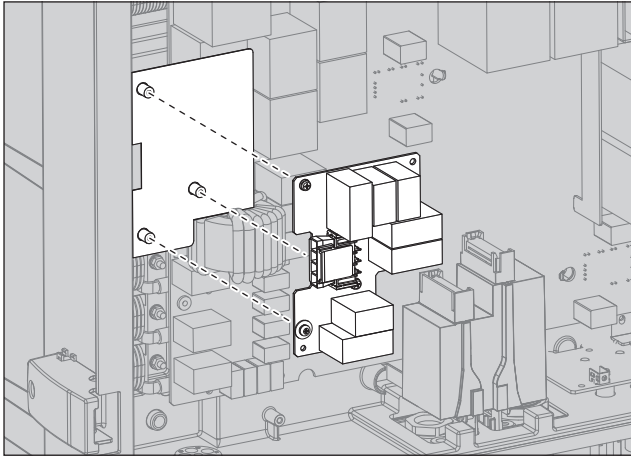

Figure 5-5: Steps of changing AC SPD

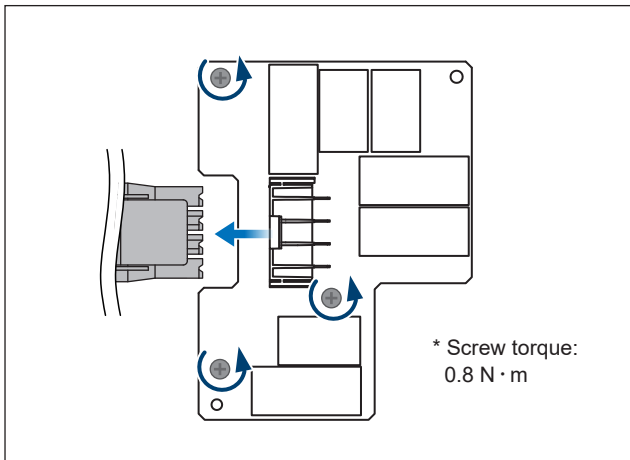

Figure 5-6: Remove wirings as connectors of AC SPD

5.2.2 Replace DC SPD

1. Turn off the AC and DC power, and wait until the LED indicators turns off.
2. Follow **Section 5.1.1** to open the door.
3. Loosen 3 screws, remove wires and disconnect signal cable to take off DC SPD.
4. Install the new DC SPD unit with procedures above in reverse order and tighten the screw with 0.8 N·m torque.
5. Follow **Section 5.1.2** to close the door.

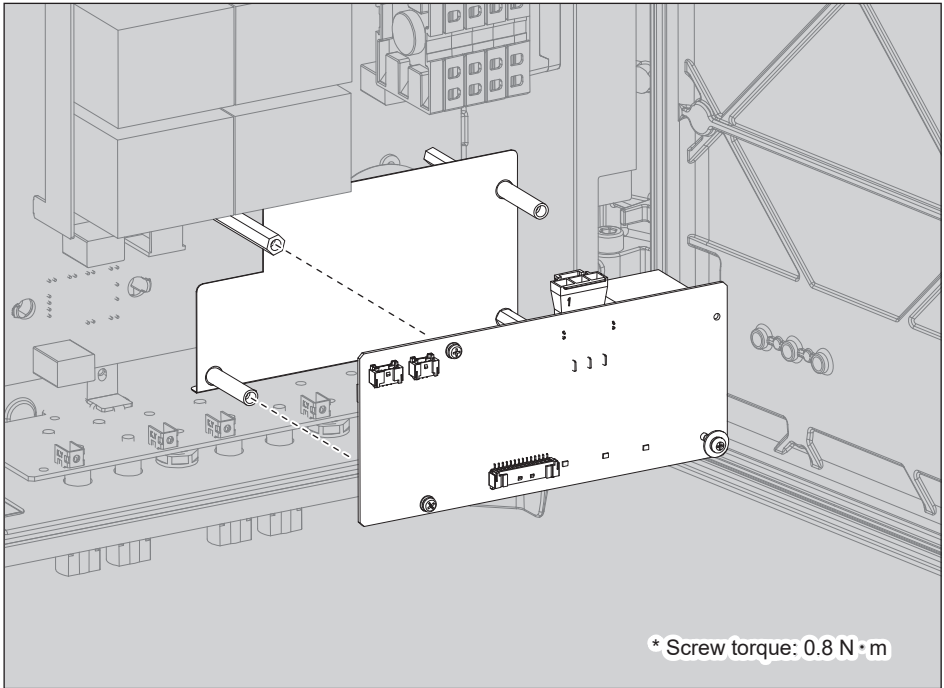

Figure 5-7: Steps of changing DC SPD

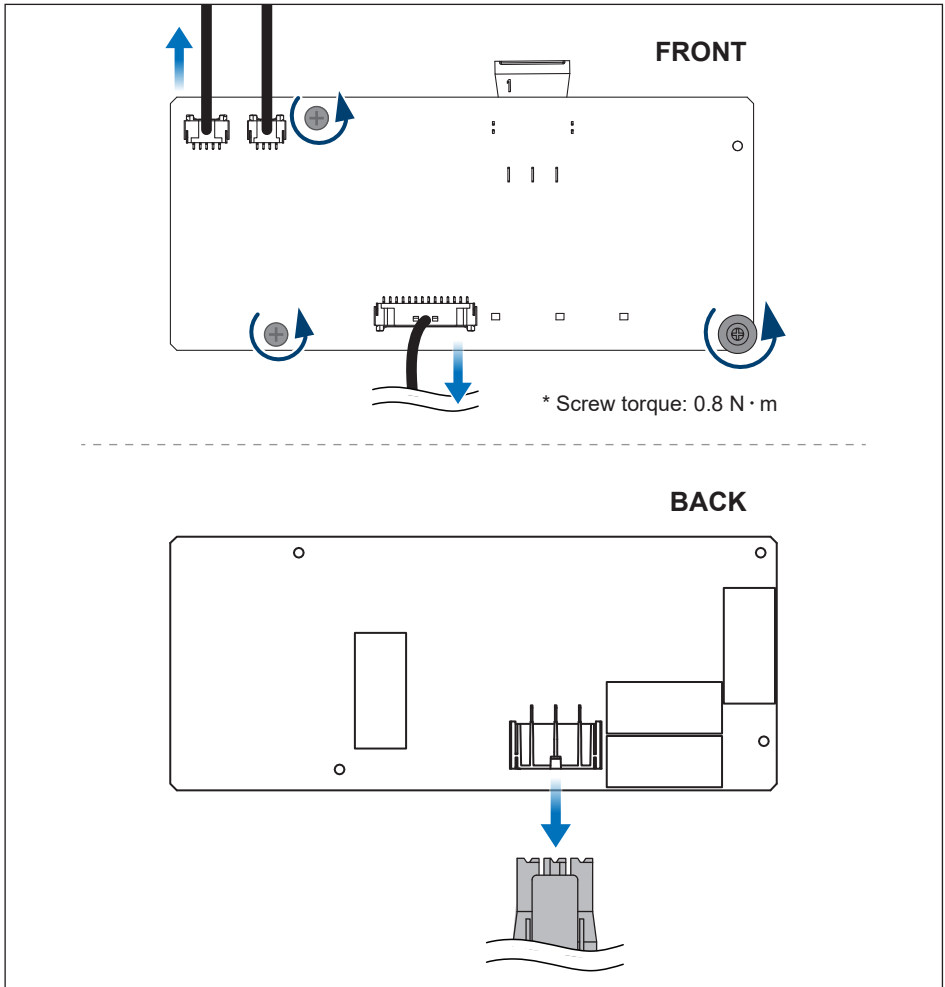

Figure 5-8: Remove wirings as connectors of DC SPD

5.3 De-Commissioning

If it is necessary to remove the inverter from active operation for maintenance or replacement, please follow the instructions below.

DANGER : ELECTRICAL HAZARD!!



To avoid serious injury, please follow the procedure below.

CAUTION : HOT SURFACES, DO NOT TOUCH !



- Please be careful of hot surfaces if the inverter is just shutting down.
- Not to do any maintenance until inverter is sufficiently cooled down.

CAUTION : POSSIBLE INJURY !



The inverter weighs more than 40 kg.

When the inverter is improperly handled or dropped during transportation or removed from the rack, it may cause personal injury.

- Switch off external AC circuit breaker or switch to disconnect the electrical grid from the inverter chassis.
- Switch off the DC switch to cease inverter operation.
- Use H4 wrench tool to disconnect each string from the chassis mounted H4 terminals.
- Remove Wi-Fi antenna from the bottom of the chassis.

■ RS-485 Communication module

1. Remove the communication module from inverter.
2. Remove all communication cables from the module terminals.
3. Reinstall the communication board assembly in inverter.

6 Error Message and Trouble Shooting

While Delta Electronics endeavors to build electronic products with high reliability standards, there may still be situations where the inverter may not operate properly. In this case, please follow the instructions in the “Troubleshooting Guide” (**Tables 6-1 ~ 6-4**) to attempt to clear the fault. If the problem can't be solved, please contact customer service for technical support.

6.1 Error Codes (Field Fault)

Table 6-1A: Error Codes (Field Fault) & Messages		
Message	Description	Action
AC Freq High (E01)	Grid frequency high	1. Check the utility frequency 2. Check Grid code & Grid setting
AC Freq Low (E02)	Grid frequency low	
Island (E03,E04,E05)	Islanding is detected	Check Grid breaker
AC phase jump (E06)	Phase jump of Grid voltage	If repeated occurrence, contact customer service for technical support
Grid Quality (E07)	Non-linear load in Grid and near to inverter	If repeated occurrence, contact customer service for technical support
AC phase abnormal (E08)	Wrong connection in AC plug	Check the AC connection in accordance with the user manual
No Grid (E09)	1. AC breaker is OFF 2. Disconnect in AC plug	1. Switch on AC breaker 2. Check the connection in AC plug and make sure it connects to inverter
AC Volt Low (E10)	1. Actual utility voltage is under the UVR setting 2. Incorrect Grid Code or Grid setting 3. Wrong connections in AC plug	1. Check the utility voltage within the suitable range 2. Check Grid code & Grid setting 3. Check the connection in AC plug
AC Volt High (E11)	1. Actual utility voltage is over the OVR setting 2. Incorrect Grid Code or Grid setting	
EPO (E25)	EPO is operated by user	Release the EPO button
DC Voltage High (E30)	Input voltage is over 1000Vdc	Modify the solar array setting, and make the Voc less than 1000Vdc
Insulation Fault (E34)	Insulation problem of PV array to ground	1. Check if panel enclosure ground completely 2. Check if inverter ground completely 3. Check if the DC breakers get wet
Remote OFF (E36)	Remote OFF by external communication	Check if remote OFF function is active

6.2 Fault Codes (Inverter Fault)

Table 6-2A: Fault Codes (inverter fault) & Messages		
Message	Description	Action
DC Injection (F01,F02,F03,F04)	Utility waveform is abnormal	Contact customer service for technical support
Temperature High (F05)	The internal ambient temperature is over limit	Check the installation ambient and environment
Amb Temp Fault (F06)	Ambient temperature detection failure	Contact customer service for technical support
Temperature Low (F07)	The internal ambient temperature is under limit	Check the installation ambient and environment
Boost Temp Fault (F08)	Boost module temperature detection failure	Contact customer service for technical support
Bidir. Temp Fault (F09)	The boost/bidir. NTC temperature	Contact customer service for technical support
Inverter Temp Fault (F10)	Inverter module temperature detection failure	Contact customer service for technical support
AC RLY Fault (F13)	1. Defective relay driver circuit 2. Relay(s) failure	Contact customer service for technical support
FW Unmatch (F14)	Firmware Incompatibility	Contact customer service for technical support
AC Sensor Fault (F15)	Auxiliary power circuit failure	1. Check the polarity of PV connection (if the error code comes along with W08) 2. Contact customer service for technical support
Vdc Sensor Fault (F16)	DSP Vdc sensor circuit defective	Contact customer service for technical support
Idc Sensor Fault (F17)	Auxiliary power circuit failure	1. Check the polarity of PV connection (if the error code comes along with W08) 2. Contact customer service for technical support
AC Sensor Fault (F18)	Auxiliary power circuit failure	Contact customer service for technical support
Idc Sensor Fault (F19)	Auxiliary power circuit failure	Contact customer service for technical support
Red COMM Fault (F22)	The internal communication connection is disconnected	Contact customer service for technical support

Table 6-2B: Fault Codes (inverter fault) & Messages

Message	Description	Action
DSP COMM Fault (F23)	The internal communication connection is disconnected	Check the connection interface RS-485
Ground Cur. High (F24)	Insulation problem of PV array to ground	1. Check the insulation of Solar inputs 2. Contact customer service for technical support
Iac Unbalance (F26)	1. Power line is disconnected 2. Current feedback circuit is defective	Check the connection in AC plug
RCMU Fault (F27)	RCMU circuit is disconnected	Contact customer service for technical support
AC RLY Short (F28)	Grid relay short	Contact customer service for technical support
AC RLY Open (F29)	Grid relay open	Contact customer service for technical support
Bus Unbalance (F30)	Voltage unbalance of DC link	Restart inverter by DC switch
Bus Voltage High (F31, F32, F33, F34, F35)	High bus capacitor voltage	1.Restart inverter by DC switch 2.Check the solar array setting, and make sure the Voc less than Max. Vdc of Inverter (if the error code comes along with E30)
AC Current High (F36,F37,F38, F39,F40,F41)	Surge occurs during operation	Contact customer service for technical support
AC CT Fault (F42,43,44)	Phase R / S / T CT is defective	Contact customer service for technical support
AC Current High (F45)	AC current over range	Restart the inverter by DC switches
ZC Circuit Fault (F50)	The zero crossing circuit is defective	Contact customer service for technical support
Inv Circuit Fault (F51)	The inverter circuit is defective	Contact customer service for technical support
Boost Circuit Fault (F52)	The boost circuit is defective	Contact customer service for technical support
Arc circuit fail (F58)	1. AFCI is not installed 2. AFCI self-test is fail	Check the AFCI detection circuit board for making sure it is connected correctly
Arc fault (F59)	The inverter detects arcing occurs	1. Check if there are any cable damaged at DC side. 2. Replace DC cable and unlock the Arc fault from DSS 3. Contact customer service for technical support

Table 6-2C: Fault Codes (inverter fault) & Messages

Message	Description	Action
DC Current High (F60,F61,F70,F71)	DC current over range	Restart inverter by DC switches
Ext COMM. Fault (F74)	The external communication connection is disconnected	1. Check the connection between external unit and COMM 2. Contact customer service for technical support

6.3 Warning Codes (Field Warning)

Table 6-3A: Warning Codes (Field warning) & Messages

Message	Description	Action
De-rating (W07)	<ol style="list-style-type: none"> Over temperature Power Limit function Power vs. Frequency function P(V) function Grid Voltage low Solar Voltage low Solar Voltage High Ramp up function 	<ol style="list-style-type: none"> Check the installation ambient and environment Check Grid Code & Grid setting Check the utility frequency on the inverter terminal Check the utility voltage on the inverter terminal 5-1. Check the utility voltage on the inverter terminal 5-2. Check reactive power setting Check the Solar voltage on the inverter terminal Check the Solar voltage on the inverter terminal Check Ramp up setting
String fault (W08)	<ol style="list-style-type: none"> Polarity of DC connectors is incorrect String current monitoring function is fail 	<ol style="list-style-type: none"> Check the polarity of PV connection Restart DC switch and AC breaker Contact customer service for technical support
String Current Low (W23)	Disconnection in DC connectors	<ol style="list-style-type: none"> Check String Connector and Fuse Contact customer service for technical support

6.4 Warning Codes (Inverter Warning)

Table 6-4A: Warning Codes (inverter warning) & Messages

Message	Description	Action
Fan Fail (W11)	<ol style="list-style-type: none"> One or more fans are locked One or more fans are defective One or more fans are disconnected 	Contact customer service for technical support
DC SPD Fault AC SPD Fault (W17) (W18)	<ol style="list-style-type: none"> One or more SPD are defective One or more SPD are disconnected 	<ol style="list-style-type: none"> Replace the defective SPD Check the connections of SPDs
Boost Circuit Fault (W30)	The boost circuit defective	Contact customer service for technical support

6.5 Earth Fault Alarm

The inverter complies with IEC 62109. When the earth fault occurs, the Yellow LED Alarm indicator will light up and a notification email will be sent to the customer.

7 Technical Information

Table 7-1A: Specifications		
Model	M15A_220	M20A_220
DC Input		
Occasionally Max. Voltage	1100 V *1	
Operating Voltage Range	200 - 1000 V	
MPP Voltage Range @ AC400V	380 - 900 V	480 - 900 V
Start Voltage	> 250 V	
Nominal DC Voltage	600 V	
Max. Input Current	25 A / MPPT, Total: 45 A	26 A / MPPT, Total: 48 A
Max. Input Power	9.85 kW /MPPT	13.5 kW /MPPT
Max. Allowable Array Isc	50A per MPPT	
MPP Tracker	2	
Connection Type	4 strings (2 pairs/MPPT), Amphenol H4 Connector	
DC Switch	Built-in	
String Monitoring	Built-in	
Arc Fault Detection	Built-in	
Surge Protection	Type II SPD	
AC Output		
Rated Output Power	15 kW	20 kW
Max. Apparent Power	16.5 kVA	22 kVA
Max. Output Power	15kW@40°C ; 16.5kW@35°C	20kW@40°C ; 22kW@35°C
Max. Output Current	25 A	32 A
Nominal AC Voltage	3 Ph 220 / 380, 230 / 400V Y or Δ	
Operating Voltage Range	80% to 130% of Nominal AC Voltage	
Operating Frequency Range	50 / 60Hz ± 5Hz	
Power Factor	0.8 ind - 0.8 cap (Adjustable)	
Surge Protection	Type II SPD	
T.H.D	< 3%	
Night Time Consumption *2	< 2 W	
Inrush Current	110 A / 50 μs	
Max. Output Fault Current (rms)	40 A	
Max. Output Over Current Protection (peak)	77 A	

*1 The max withstand voltage is 1100Vdc. (Inverter stops output when the PV voltage is over 1000Vdc)

*2 Night time consumption with standby communication.

Table 7-1B: Specifications		
Model	M15A_220	M20A_220
Efficiency		
Peak Efficiency	98.4 %	98.5 %
Euro Efficiency	97.9 %	98.1 %
Information		
Communication Port	RS-485 / Wi-Fi	
Regulation		
Grid support	IEC 62920 IEC 61439-2 IEC 62109-1/-2 CNS 15382 CNS 15426-1/-2	VDE-AR-N 4105 VDE-AR-N 4110 EN/IEC 61000-6-1/-2 EN/IEC 61000-6-3/-4 AS4777.2 : 2020
General Data		
Operating Temp. Range	-25 to +60°C (Derating Above 40°C)	
Protection Level	IP66	
Operating Elevation	< 4000 m	
Cooling	Natural cooling	
Noise	31.6 dBA @1m, Amb25°C	
Dimension (W x H x D)	651 x 520 x 220 mm	
Weight	40.5 kg	
Relative Humidity	0%-100% non-condensing	
Pollution Degree	II	
Overvoltage Category	AC Output: III, DC Input: II	
Back-Feed Current to the Array	0	
Galvanic Isolation	No	

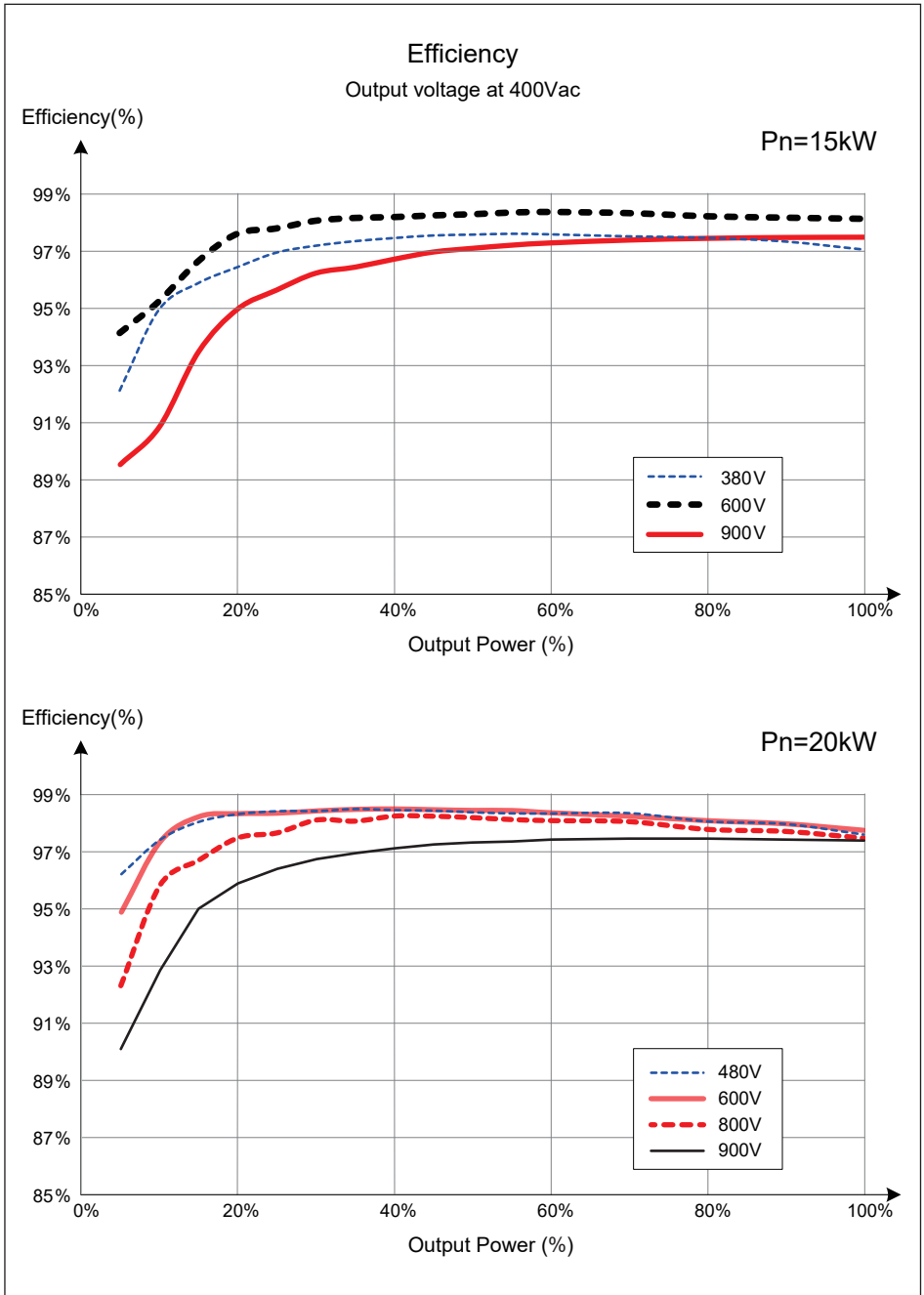

Figure 7-1: Efficiency Curve

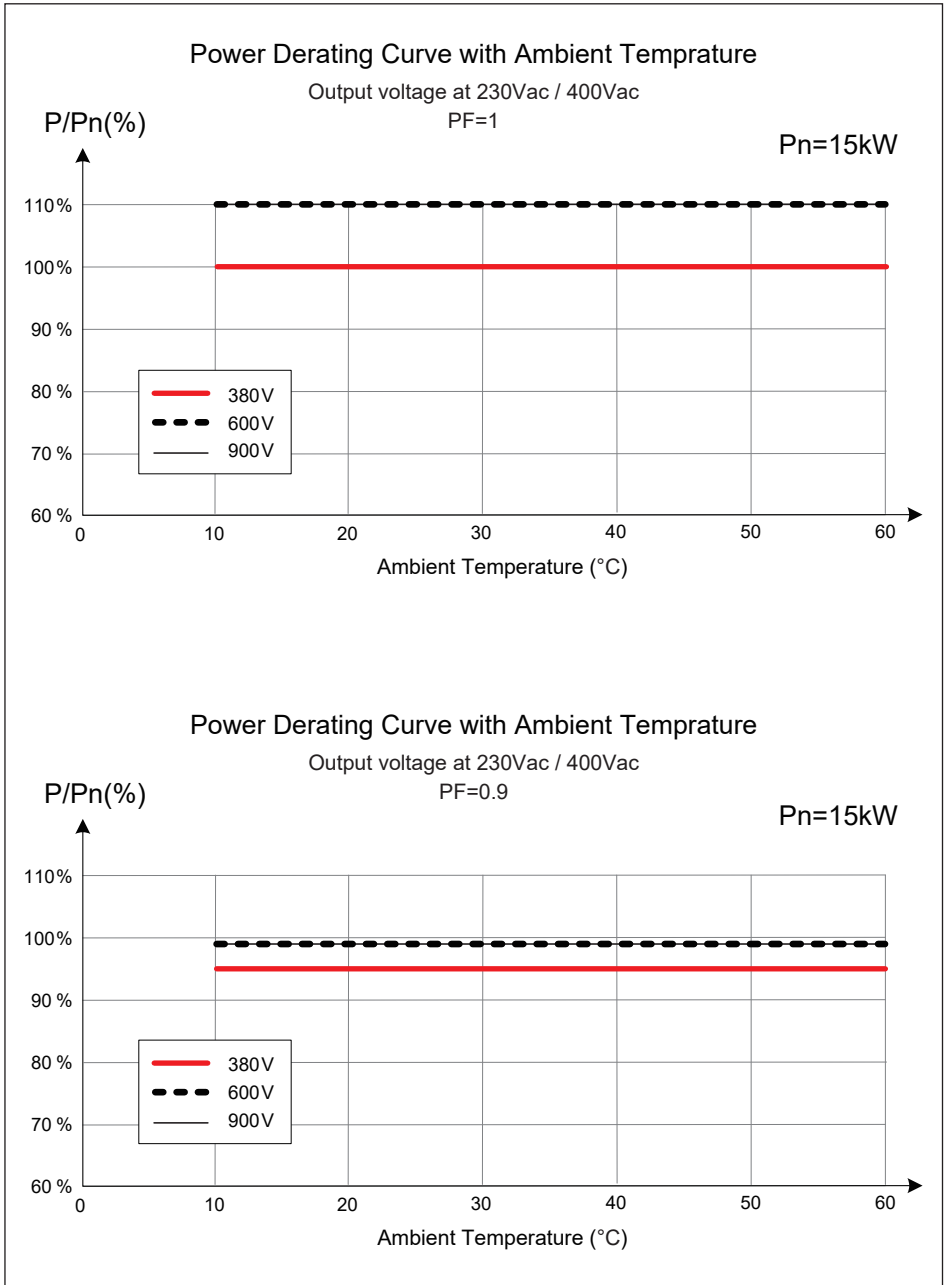

Figure 7-2: Power Derating Curve with Ambient Temperature (M15A_220)

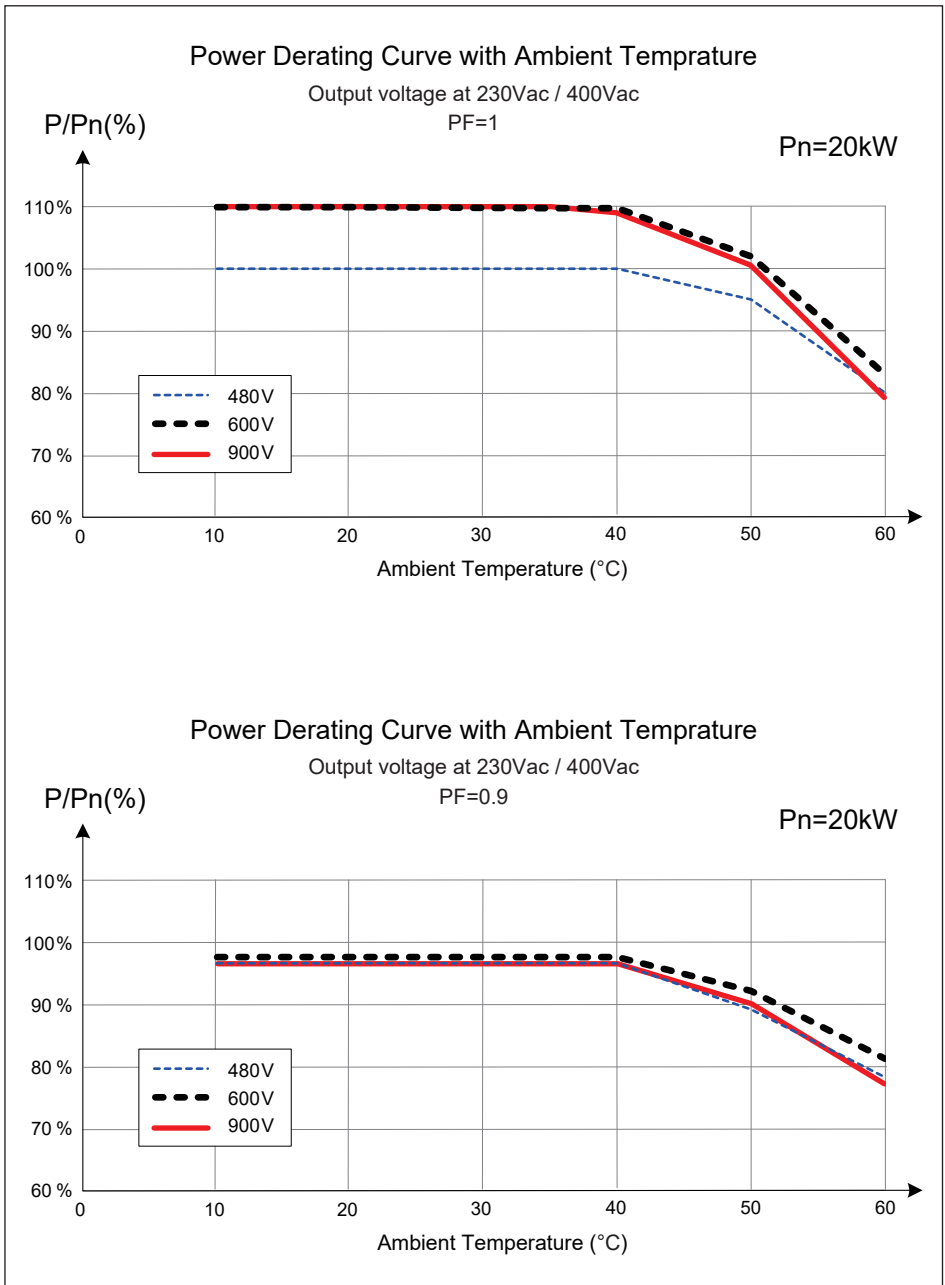

Figure 7-3: Power Derating Curve with Ambient Temperature (M20A_220)

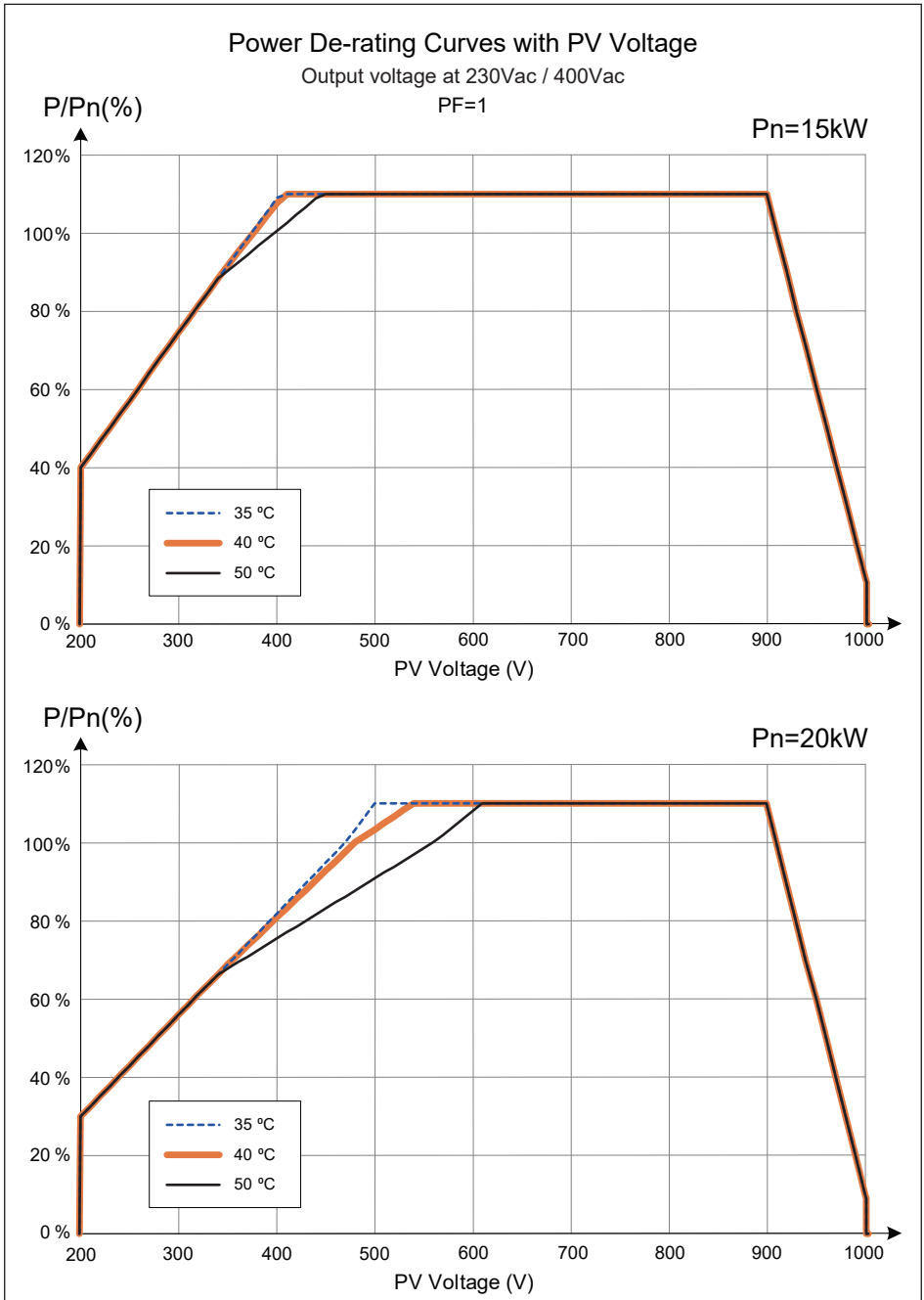
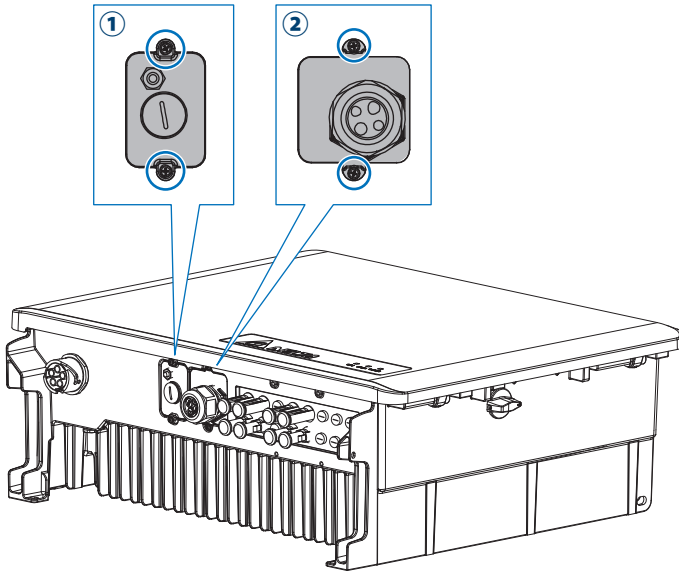

Figure 7-4: Power De-rating Curves with PV Voltage

Appendix: Assembly Note



Appendix-1: Assembly Note-1

NO	Location	Screw torque
1	Wi-Fi module cover	8.0 kgf-cm (0.8N · m)
2	Communication cover	8.0 kgf-cm (0.8N · m)

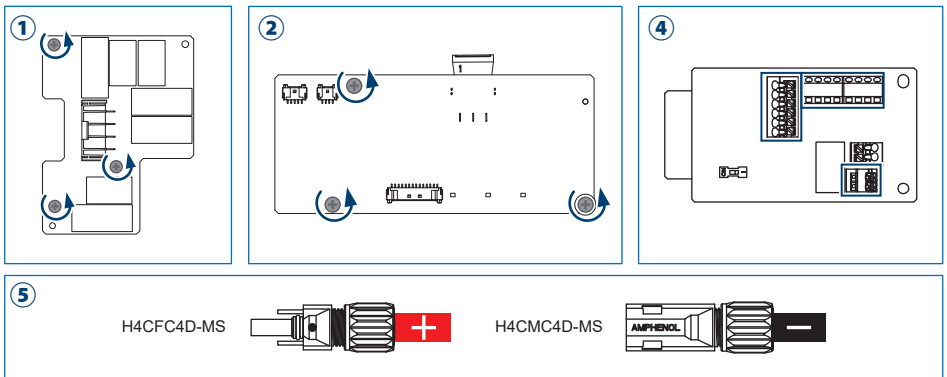
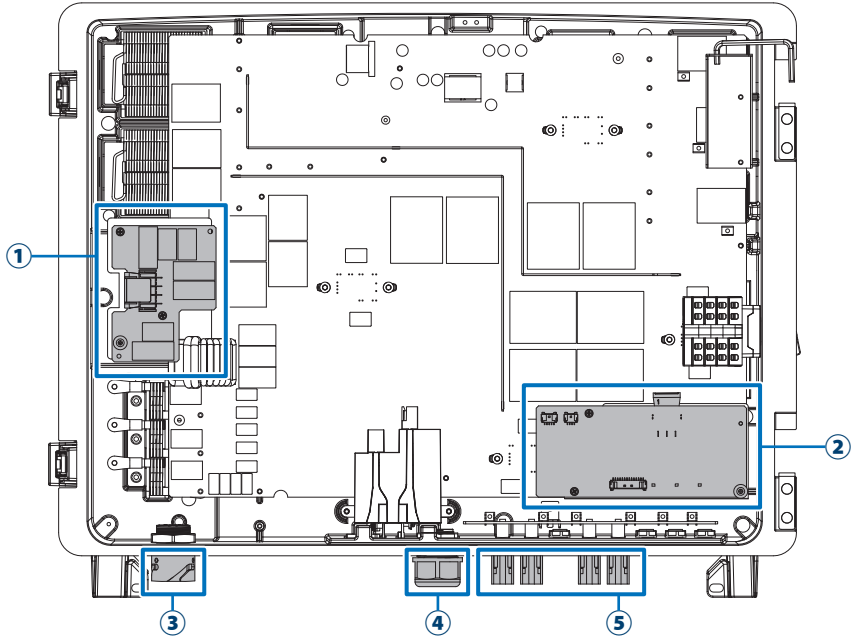

Appendix-2: Assembly Note-2

NO	Location	Screw torque	Conductor cross-section
1	AC SPD board	8.0 kgf-cm (0.8N · m)	-
2	DC SPD board	8.0 kgf-cm (0.8N · m)	-
3	AC wire	7.1 kgf-cm (0.7N · m)	8 AWG (8 mm ²)~6 AWG (14 mm ²)
4	Communication port	-	20 AWG (0.5mm ²)
5	H4 wire	-	12/10 AWG (4/6mm ²)



三相併網型變流器

M15A_220 / M20A_220
操作手冊

English 1

繁體中文 63

www.deltaww.com

 **DELTA**
Smarter. Greener. Together.

Contents

1	安全規範	70
1.1	變流器資料	70
1.1.1	免責聲明	70
1.1.2	適用對象	70
1.2	安全概述	71
1.2.1	使用條件	71
1.2.2	標誌	72
2	產品介紹	74
2.1	適用機種	74
2.2	產品概述	75
3	安裝	78
3.1	拆箱與檢視	79
3.2	直立壁掛式安裝	81
3.3	交流配線安裝	83
3.3.1	AC 形式與連接方式	85
3.3.2	必要保護裝置	85
3.3.3	多台變流器並聯安裝要求	85
3.3.4	交流配線安裝	86
3.3.5	交流配線	87
3.4	直流配線安裝	89
3.5	設備接地	92
3.6	通信模組配接方式	93
3.6.1	連接通訊模組	94
3.6.2	RS-485 連線	95
3.6.3	EPO 緊急關斷功能與數位輸入	97
3.6.4	乾接點連接說明	98
3.7	Wi-Fi	99

4	試運行	100
4.1	LED燈號介紹	100
4.2	自動ID設定	101
4.2.1	DSS連接	101
4.2.2	掃描變流器	102
4.2.3	ID設定	103
4.2.4	國別設定	104
4.2.5	時間同步設定	104
4.3	Delta功能設定	105
5	維護	106
5.1	開啟與關閉前蓋	106
5.1.1	開啟前蓋	106
5.1.2	關閉前蓋	107
5.2	更換雷擊保護裝置 (SPD)	108
5.2.1	更換AC SPD模組	109
5.2.2	更換DC SPD模組	110
5.3	終止運轉	112
6	錯誤告警及排除問題	113
6.1	錯誤訊息(配置端故障)	113
6.2	故障訊息(變流器故障)	114
6.3	警告訊息(配置端警告)	116
6.4	警告訊息(變流器警告)	116
7	技術資料	117
	附錄: 組裝說明	123

Figure

圖 2-1: 內容物	75
圖 2-2: 外觀介紹	76
圖 2-3: 標籤	77
圖 3-1: 開箱步驟	79
圖 3-2: 安裝吊鈎	80
圖 3-3: 變流器尺寸	81
圖 3-4: 壁掛架尺寸	82
圖 3-5: 壁掛螺絲鎖附位置	82
圖 3-6: 機台間最低要求距離	83
圖 3-7: 正確與禁止的安裝方式	83
圖 3-8: 交流線材剝線	86
圖 3-9: 組裝交流接頭	87
圖 3-10: 交流電纜密封套規格	87
圖 3-11: 交流接線	88
圖 3-12: 組裝交流接頭	88
圖 3-13: 直流感線安裝	90
圖 3-14: H4 端子與光伏組串對照圖	91
圖 3-15: 外部接地點	92
圖 3-16: 通訊模組	93
圖 3-17: 通訊模組位置與連接	94
圖 3-18: 多台併接通訊示意圖	96
圖 3-19: 緊急關斷功能端子座	97
圖 3-20: 乾接點連接位置圖	98
圖 3-21: Wi-Fi天線安裝	99
圖 4-1: 顯示面板	100
圖 4-2: DSS連接	101
圖 4-3: 變流器掃描	102
圖 4-4: 設定ID	103
圖 4-5: 國別設定	104
圖 4-6: 時間同步設定	104

圖 5-1: 開啟與關閉前蓋	106
圖 5-2: 使用六角板手將前蓋固定	107
圖 5-3: 交流與直流側雷擊保護裝置位置	108
圖 5-4: 交流與直流側的雷擊保護裝置	108
圖 5-5: AC SPD更換步驟	109
圖 5-6: 移除AC SPD 螺絲與排線	109
圖 5-7: DC SPD更換步驟	110
圖 5-8: 移除DC SPD 螺絲與排線	111
圖 7-1: 效率曲線圖	119
圖 7-2: 環溫對應降額曲線圖(M15A_220)	120
圖 7-3: 環溫對應降額曲線圖(M20A_220)	121
圖 7-4: 環境溫度對應輸出能力降額曲線	122

Table

表 2-1: 內容清單	75
表 2-2: 外觀介紹	76
表 2-3: 標籤內容描述	77
表 3-1: 交流線材規格	86
表 3-2: RS-485 端子座說明	95
表 3-3: 終端電阻設定說明	96
表 3-4: 數位輸入與EPO功能說明	97
表 4-1: LED 指示燈	100
表 4-2: LED 通訊指示燈	100
表 6-1A: 錯誤代碼(配置端故障)	113
表 6-2A: 故障代碼(變流器故障)	114
表 6-2B: 故障代碼(變流器故障)	115
表 6-2C: 故障代碼(變流器故障)	116
表 6-3A: 警告代碼(配置端警告)	116
表 6-4A: 警告代碼(變流器警告)	116
表 7-1A: 規格	117
表 7-1B: 規格	118
附錄-1: 組裝說明-1	122
附錄-2: 組裝說明-2	123

1 安全規範

1.1 變流器資料

1.1.1 免責聲明

著作權~ DELTA ELECTRONICS, INC. - All rights reserved.

本說明書及產品供終端使用者使用。技術資料及內圖文皆為機密資料且不經 DELTA ELECTRONICS, INC. 許可，禁止複製翻印。

維修工程師及終端使用者禁止洩漏內涵之訊息及除以正確使用本產品以外的目的使用本說明書。所有資訊若有變更，不另外通知。

DELTA ELECTRONICS, INC.針對以下情形造成的損害將不負任何責任及義務：

- (a) 產品沒有恰當的安裝或維修
- (b) 產品未依照說明書正確使用
- (c) 產品於拆裝過程受損

1.1.2 適用對象

本說明書適用於針對安裝、試運行、實際操作、後續維護受過良好訓練的人以下基礎及進階技巧為必需的。

- 了解基礎電力、配線、電子元件及電子電路符號
- 了解太陽能變流器如何運行及操作
- 針對電子產品的安裝及試運行受過訓練
- 針對安裝及使用電子產品的過程中會遇到的危險及風險受過訓練
- 遵守本說明書及所有安全規範

開始接觸此產品前，請詳閱本說明書。

1.2 安全概述

重要安全指示：保存所有指示！



- 請詳閱所有指示及保存供後續使用。

為了避免人員受傷或其他損失及確保變流器長期運轉，在使用此產品前請務必詳閱所有安全指示。

本說明書針對DELTA併網型無變壓器太陽能變流器提供重要指示。本產品進行設計、測試、驗證且經國際安全規範認證，但安裝及使用本產品前仍須做好防範措施。本產品適用於室內及戶外。

注意：無電氣隔離



- 本產品無附加變壓器，為非電氣隔離型。
- 請勿使用需接地(正極或負極)之太陽能板。
- L1, L2, L3,及 N 禁止連接至地。

1.2.1 使用條件

- M15A_220 / M20W_220 為 3 MPP追蹤、無變壓器太陽能變流器，能將太陽能串列的變動電流轉換成與市電頻率相同之三相交流能量並饋入市電。
- 所使用之太陽能模組需與變流器匹配。
- 太陽能面板之對地電容不可超過 5 μ F。
- 本產品僅可在經DELTA及市電業者許可之國家運行。

1.2.2 標誌

本節說明本說明書會出現的標誌定義，為了避免人員受傷或其他損失及確保變流器長期運轉，在使用此產品前請務必詳閱所有安全指示並遵守。

危險！



- 此警語表示非正確的行為將會造成致死或嚴重傷亡的危險。

警告！



- 此警語表示存在致死或嚴重傷亡的危險。

注意！



- 此警語表示可能造成輕微的傷害。

注意



- 此警語表示可能對資產或環境造成傷害。

資訊



- 進一步的資訊會經由雙圈驚嘆號指示。
這代表接續的內容將含有使用者該遵守的重要資訊以免造成任何傷害。

危險：觸電!!



- 此警語表示非正確的行為將會造成致死或嚴重傷亡的電擊危險。

注意：表面高溫，請勿觸碰！



- 此警語表示當變流器運行時機體表面高溫。
- 請著防護裝備或待表面溫度下降後再進行需接觸的工作。



- 等待圖示中所顯示的時間後再進行工作



- 設備接地導體

2 產品介紹

M15A_220 / M20A_220 以最先進之高頻切換及低EMI技術設計而成，同時具有高效率及高壽命的特點，亦適用於戶外。

注意：無電氣隔離



- 本產品無附加變壓器，為非電氣隔離型。
- 請勿使用需接地(正極或負極)之太陽能板。
- L1, L2, L3,及 N 禁止連接至地。

2.1 適用機種

本說明書適用以下機種:

- M15A_220
- M20A_220

安裝、運行及維護過程皆必須遵守本說明書。

DELTA保留在不另行告知的前提下修改內容及技術資料的權力。

2.2 產品概述

內容物如圖2-1所示。



圖2-1：內容物

表2-1：內容清單

M15A_220 / M20A_220			
	物件	數量	描述
1	DELTA太陽能變流器	1	太陽能變流器
2	壁掛架	1	將變流器掛起之壁掛架 (材質: 鋁 / 厚度: 3mm)
3	說明書	1	安裝及維運過程中務必參考本說明書中的安全指示
4	交流端接頭	1 組	交流端接頭
5	H4端子	4 對	直流組串輸入接頭
6	H4扳手	2	H4接頭拆除工具
7	六角板手 (已安裝於鎖扣外蓋上)	1	固定前蓋用門門與卸除鎖扣外蓋螺絲工具
8	Wi-Fi 天線	1	Wi-Fi專用天線
9	資安封條	6	用於資安檢測的一次性貼紙

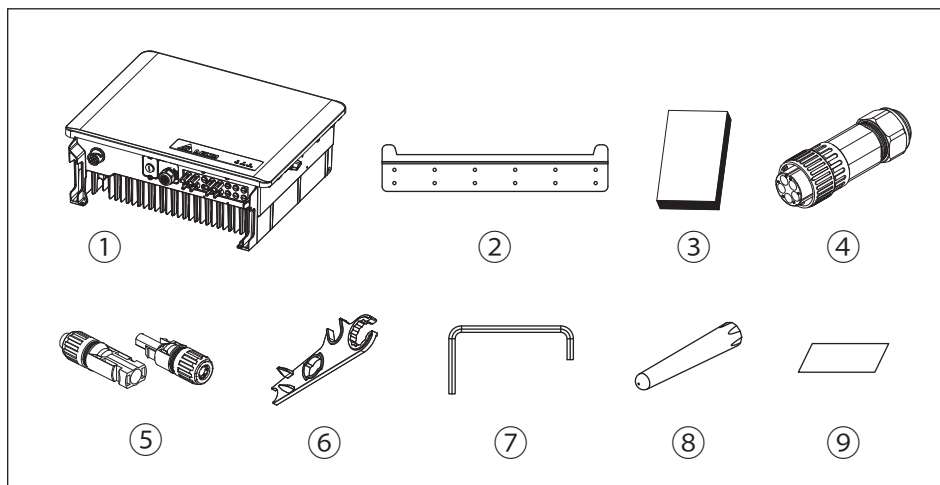

圖 2-2 : 外觀

表 2-2 : 外觀介紹

NO.	部件	NO.	部件	NO.	部件
1	鎖扣	2	LED	3	直流開關
4	保留孔*	5	交流輸出	6	Wi-Fi 天線孔
7	通訊接線孔	8	直流輸入 (H4) x 4 strings		

*保留孔未使用時，請勿將螺母及螺絲卸除，以維持防塵防水效果。

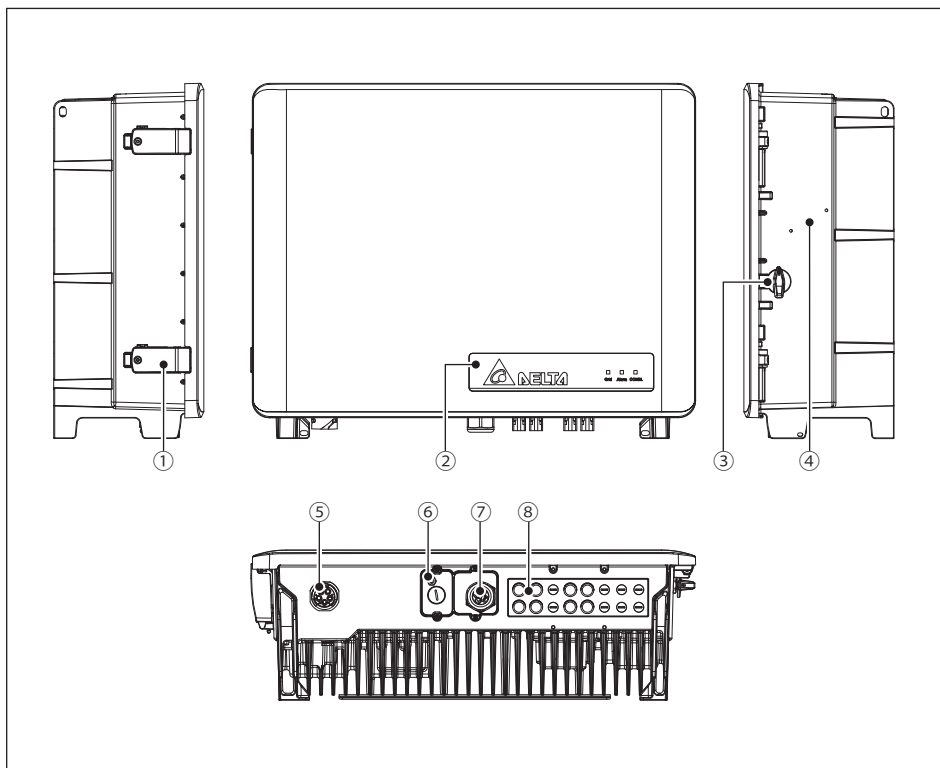
圖2-3為產品標籤並配合表2-3針對特殊符號做解釋。







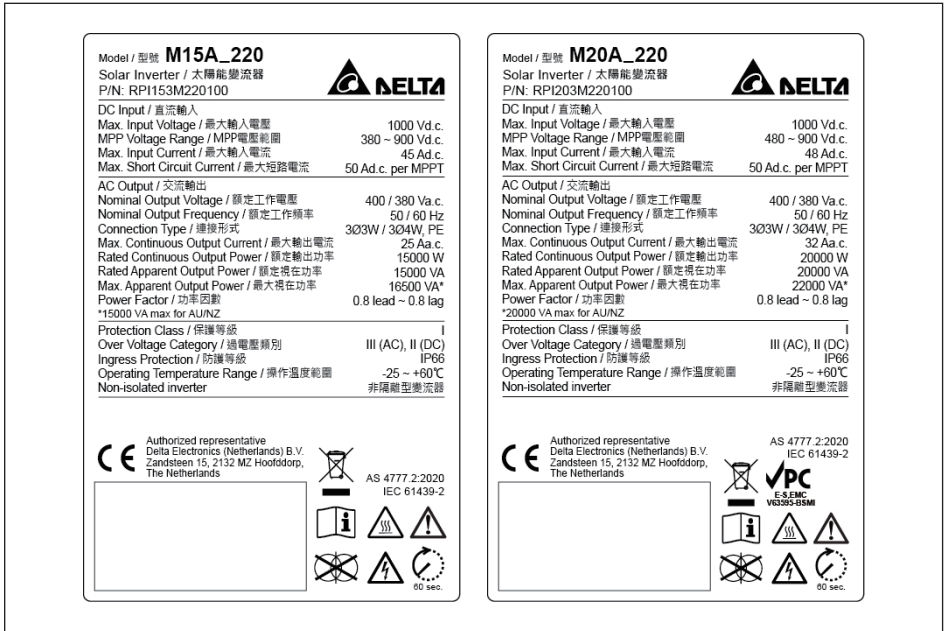

圖2-3：標籤

表2-3：標籤內容描述

符號	定義
	嚴重觸電危險 變流器運行時會有致命高電壓存在，切斷後危險電壓存在約60秒，時間內請勿接觸變流器。 本產品不含任何需要開啟機殼之元件。擅自開啟機殼會使保固失效。
	注意表面高溫 變流器運行時，表面可能高溫
	此變流器本身沒有經由變壓器與市電端分離。
	若當地規範要求，機體外殼請務必下地。
	使用此變流器前，請詳閱說明書。
	WEEE marking 本變流器須以標準家用廢棄物報廢，並同時遵守當地針對電器報廢的相關規範。

3 安裝

警告！



- 請勿將本產品安裝在易燃表面附近。
- 請將本產品安裝於堅固且平順之表面。

注意！



- 高溫可能導致降額功率輸出，本產品不建議安裝在直接日照曝曬處。
- 搬起變流器時請注意安全，墜落可能導致人員受傷。

注意！



本產品支援無線通訊方式。

- 確保產品安裝位置遠離發射強無線電波的設備（例如民用頻段無線電設備）。
- 避免將產品安裝在金屬箱內，並確保產品與連接設備之間沒有金屬阻擋物，以防止通訊訊號衰減。
- 使用Wi-Fi功能連接設備時，訊號強度建議為-70 dBm以上，以確保提供良好的通訊品質。

本章節包含以下指示

1. 壁掛安裝 2. 電氣安裝 3. 通訊安裝

3.1 拆箱與檢視

請依照圖 3-1 所示拆封外箱包裝。
起重機吊鉤安裝位置如圖 3-2 所示。



圖 3-1: 開箱步驟



圖 3-2: 安裝吊鈎

3.2 直立壁掛式安裝

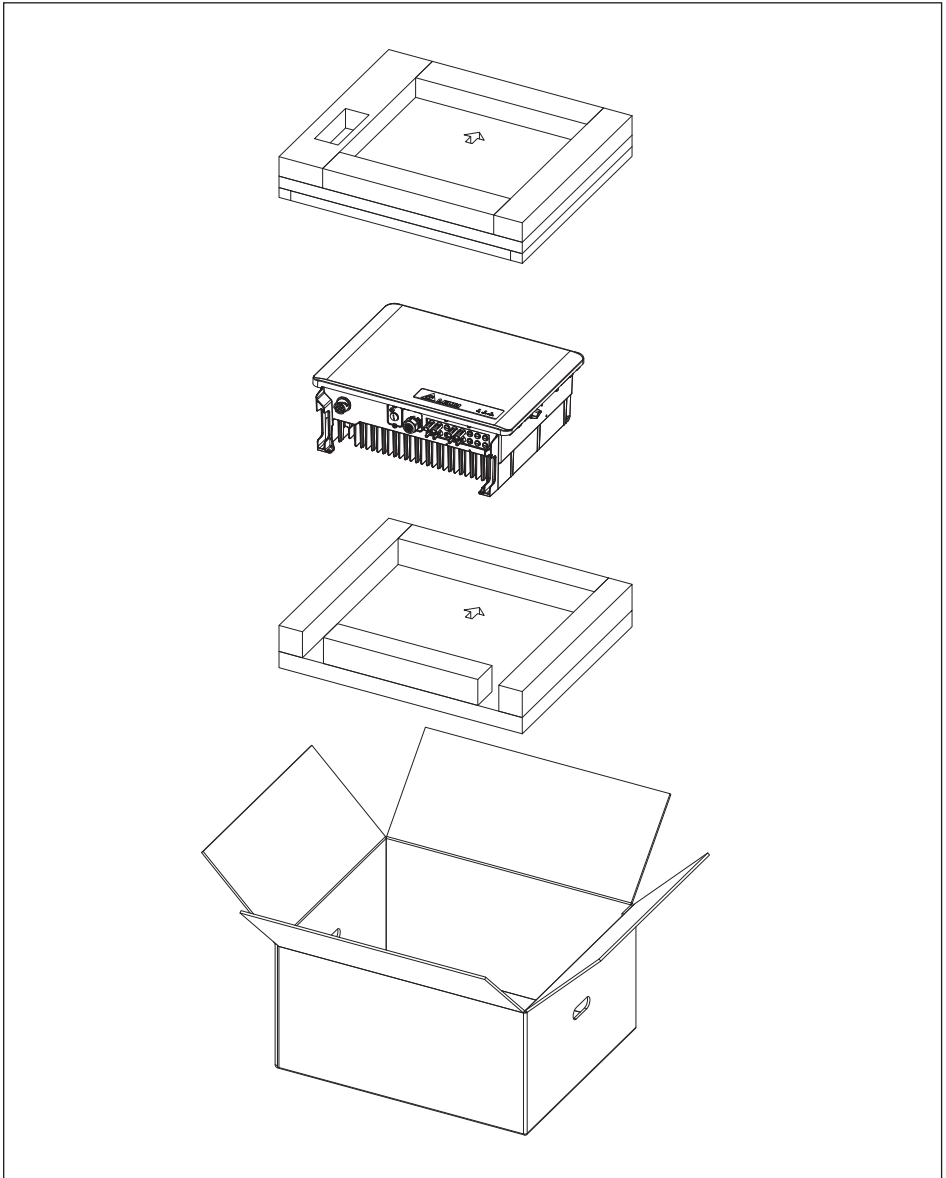
1. 請先確定產品安裝牆面為足以承載產品重量。
2. 水平固定壁掛架(垂直於地板)·壁掛架尺寸如圖3-4所示。
3. 鎖附12枚M6十字螺絲於壁掛架上。(圖3-5)
4. 將產品放置於壁掛架上。
5. 將產品鎖附上2枚M5十字螺絲於圖3-5所示之位置。
此處亦為設備外部接地點·設備接地方式請參閱3.5章。

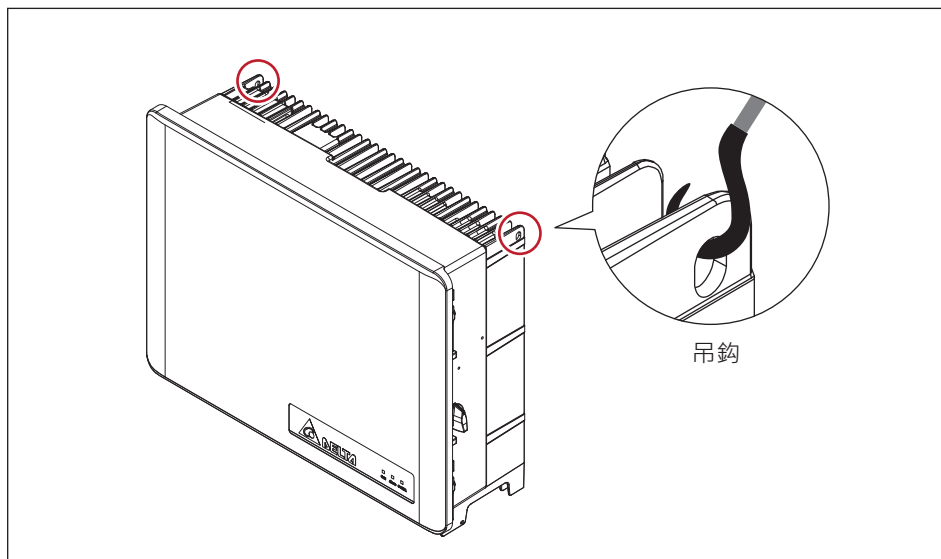

圖 3-3: 變流器尺寸

注意！

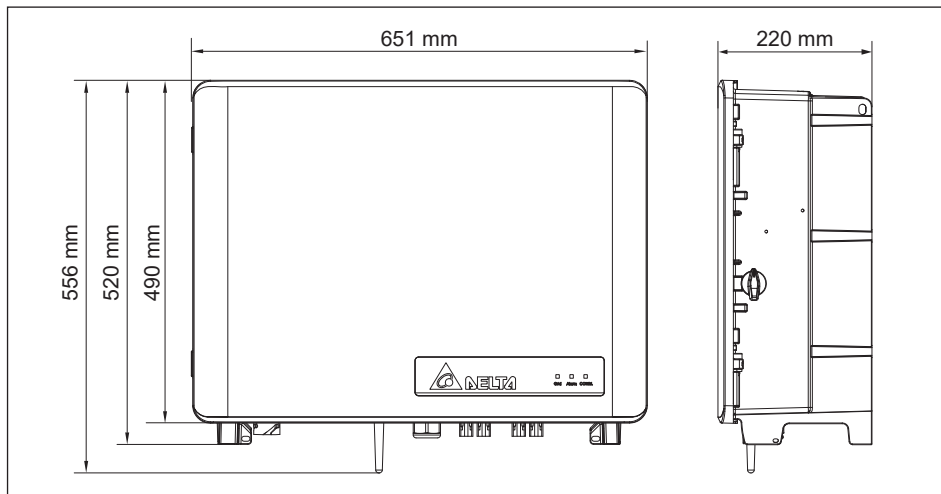

- 至少使用6枚M6螺絲將壁掛架固定牆上。
- 該壁掛架為本產品專用·請勿使用其他壁掛架來搭配本產品使用。
- 未遵守以下安裝說明中的方向和間隙可能導致降額功率輸出並可能使保固失效。

注意！



為避免由於極端氣候(大雪, 冰雹...等)或不恰當的安裝/維運所導致的變流器故障, 台達強烈建議安裝額外的保護蓋·詳細細節請洽當地服務團隊。

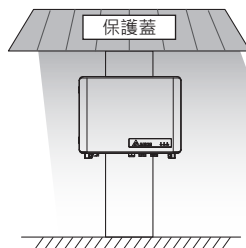



圖 3-4: 壁掛架尺寸



圖 3-5: 壁掛螺絲鎖附位置

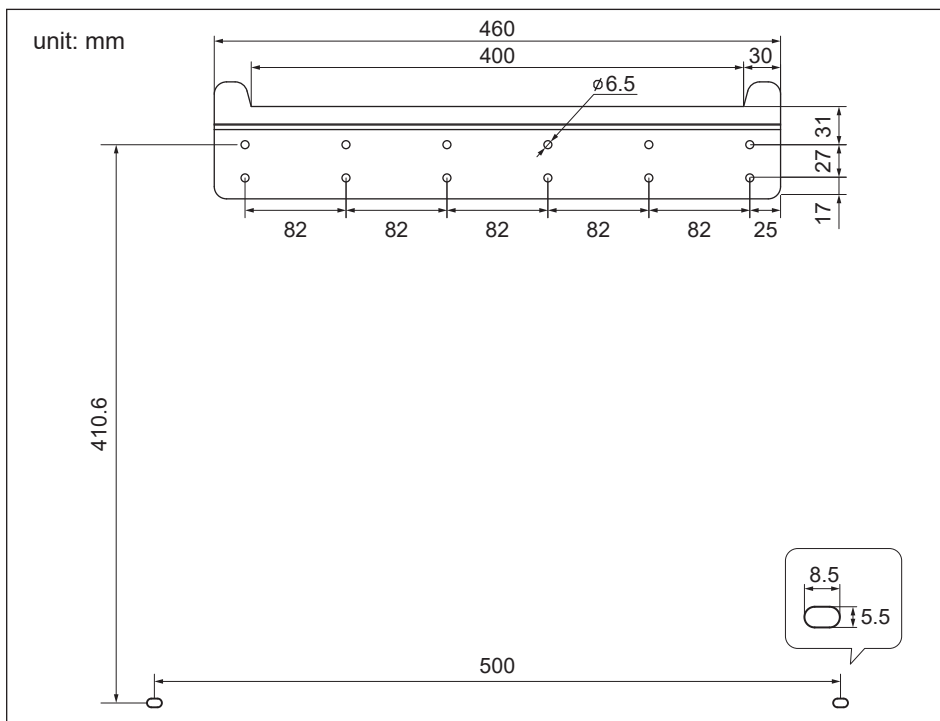

圖 3-6: 機台間最低要求距離

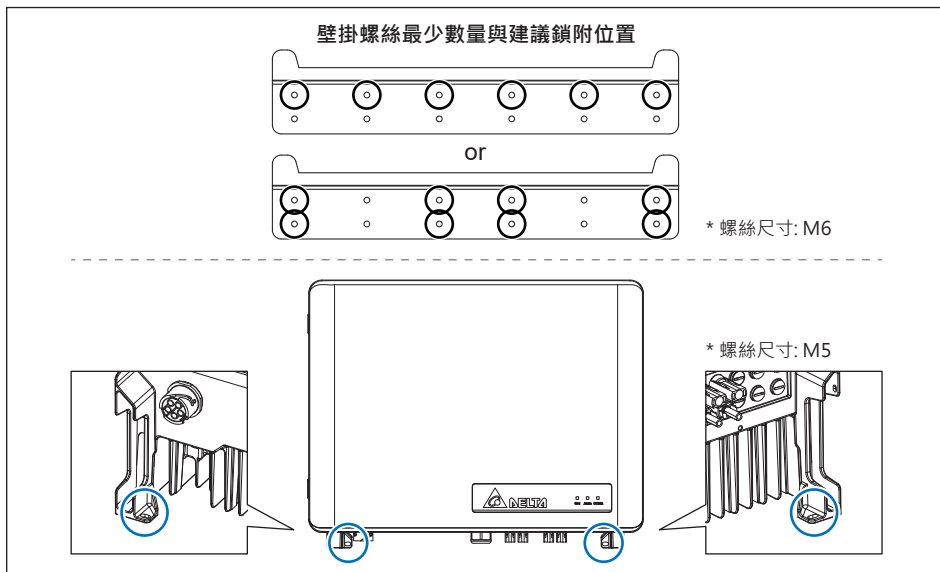

圖 3-7: 正確與禁止的安裝方式

3.3 交流配線安裝

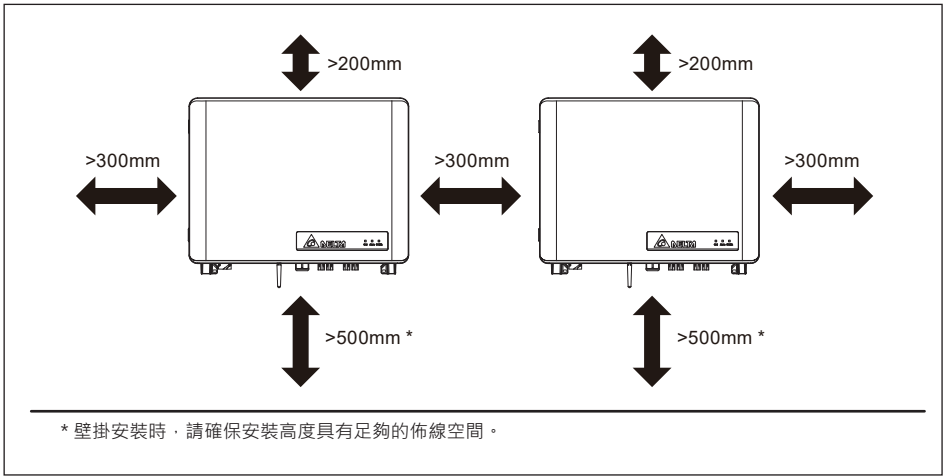
危險：觸電危險!!

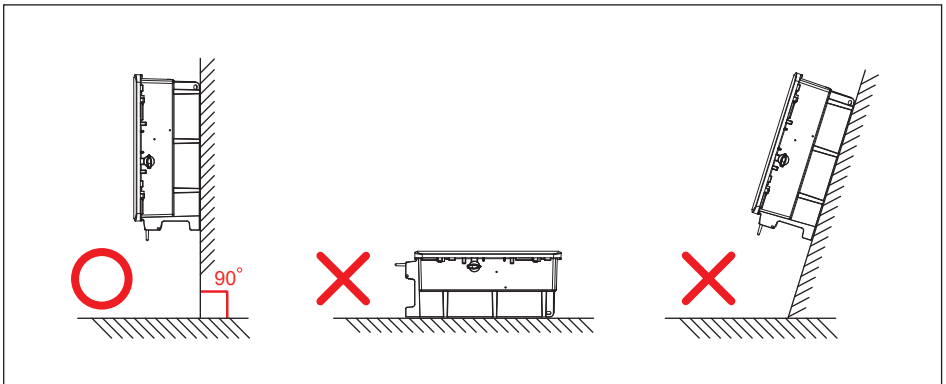

- 配線時禁止供給變流器任何電源。

警告！



- 遵守條文為安裝者的責任。

注意：變流器及設備可能損毀！



- 交流接頭安裝須遵守當地電氣法規。
- 不遵守指示可能會損壞交流線材。
- 當安裝說明與當地電氣法規之間存在衝突，請遵循電器法規。

注意



- 灰塵侵入可能會導致變流器毀損。
- 請勿開啟變流器前蓋

3.3.1 交流形式與連接方式

注意



機器初始設定為3Ø-4W接線方式，也可變更為3Ø-3W不含中性點N的接線方式。變流器可工作於下述電力系統連接方式無須額外配接外部變壓器。

TNC system

220/380V, 230/400V

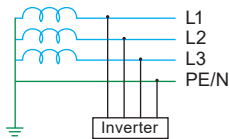

TNC-S system

220/380V, 230/400V

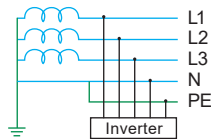

TNS system

220/380V, 230/400V

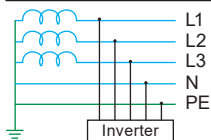

TT system

220/380V, 230/400V

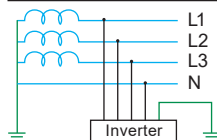

IT system

220/380V, 230/400V

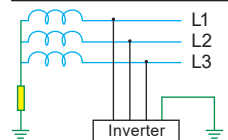

3.3.2 必要保護裝置

建議於市電端與變流器間加入隔離及過電流保護裝置，請依據當地電工法規設計裝置規格。

3.3.3 多台變流器並聯安裝要求

多台變流器並聯連接到電網時，最多可連接 30 台變流器至變壓器的單個繞組上。

3.3.4 交流配線安裝

交流端之配線必須妥善包覆以確保安全並符合表3-1之規格。
當以下規格與當地電氣法規之間存在衝突，請遵循電器法規。

表3-1: 交流線材規格

單一線徑範圍	電纜直徑	鎖線扭矩值
8~14 mm ² (8~6 AWG)	20~26 mm	1.8~2.5 N·m

在組裝交流接頭前請先按照以下步驟剝除線皮：

- 剝除電纜外部膠皮70 mm
- 剝除內部所有線材之膠皮 22 ± 2 mm



圖3-8 : 交流線材剝線

注意：變流器及設備可能損毀！

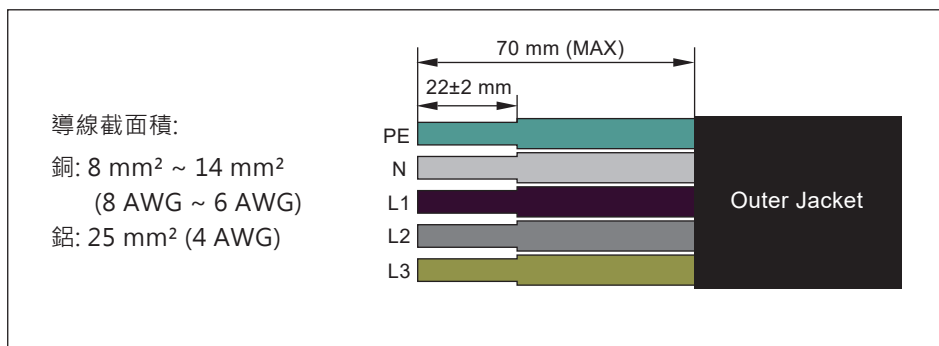

- 未使用正確線材線徑可能使線材鎖附不牢固，導致接頭損毀狀況發生。
- 交流接頭之裝配須符合當地電氣法規，若此安裝說明與法規有所抵觸，請遵循電器法規。

3.3.5 交流配線

1. 產品包裝中附有一組交流接頭配件，請將接頭拆解成A和B兩個部分 (圖 3-9)
2. 將妥善包覆後的交流電纜安裝至A部分(電纜密封套)，並將電纜內部的交流線材依下圖所示之扭矩值分別鎖附至B部分 (圖 3-11)
3. 將A和B兩個部分妥善組裝如圖3-12所示，組裝完成後再安裝至變流器交流端對應接頭上



圖 3-9：組裝交流接頭



圖 3-10：交流電纜密封套規格

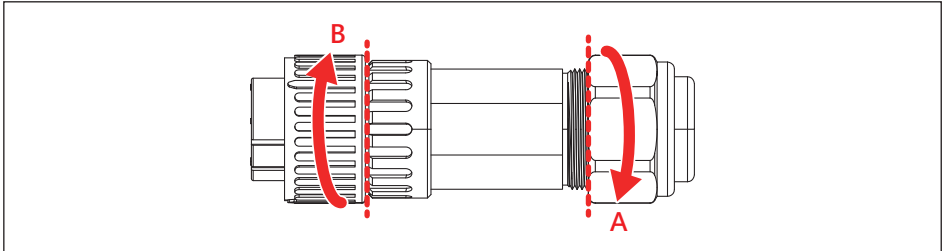

圖 3-11：交流接線

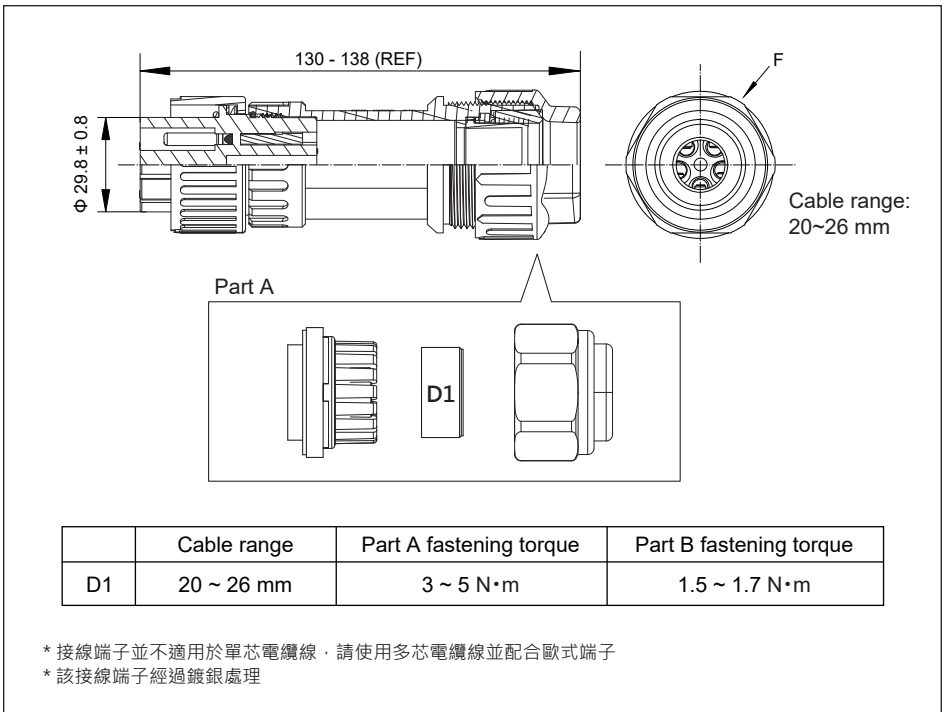

圖 3-12：組裝交流接頭

3.4 直流配線安裝

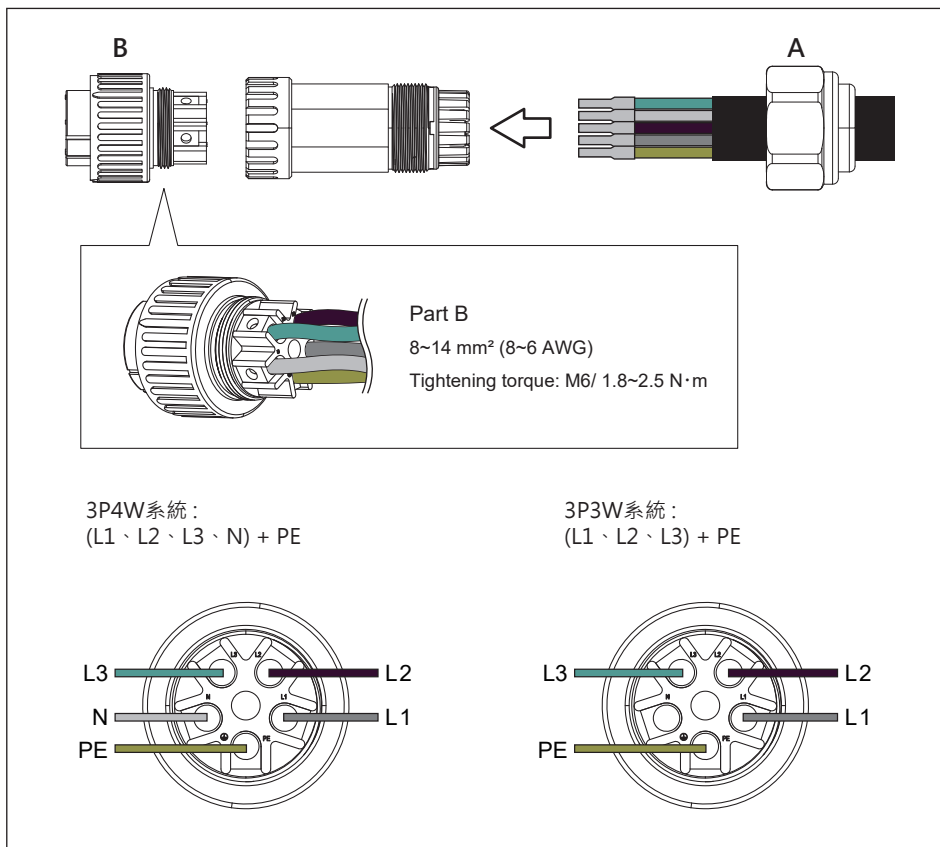
危險:觸電危險!!

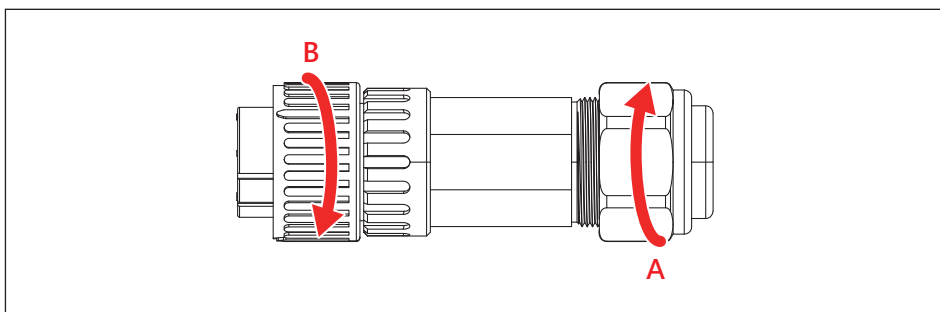

- 太陽能串列將太陽能轉換成高壓直流形式，此高壓有可能造成觸電危險。
- 配線前請使用非透明物質將太陽能串列遮蓋起來。
- 配線時請確認電壓極性。
- 同一組MPPT下各組串的模組數量需相同，以降低模組間環流問題。

警告!



- 在錯誤的情況下，變流器可能引發觸電及火災危險。
- 僅允許使用有標示低於1100V的太陽能串列。
- 配線時請確認直流開關在"關"的模式，且太陽能陣列沒有連接。
- 直流電壓超過1100V則保固失效。

注意

- 太陽能陣列的正或負端皆禁止接到地。
- 在安裝直流端子時，請務必確認端子極性是否正確，錯誤的極性，將可能導致變流器造成損壞。

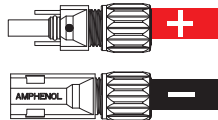

- 未使用的DC串列輸入端子，請勿移除防水塞。

3.4.1 直流接線安裝

連接時請遵循以下步驟：

- 請使用材質為銅的導線，並確認尺寸符合NEC或當地法規。
 - 剝除6.5-7.5mm的電線外皮。
 - 每根直流導線的橫截面積為12/10 AWG (4/6mm²)。
- 直流端導線分為正負極配接，其配線方式如圖3-13~3-14所示。

M15A_220 / M20A_220 使用H4端子连接到變流器。
外部配線用端子附於配件包中(表2-1, 配件5)。



圖 3-13: 直流接線安裝



圖 3-14 : H4 端子與光伏組串對照圖

注意

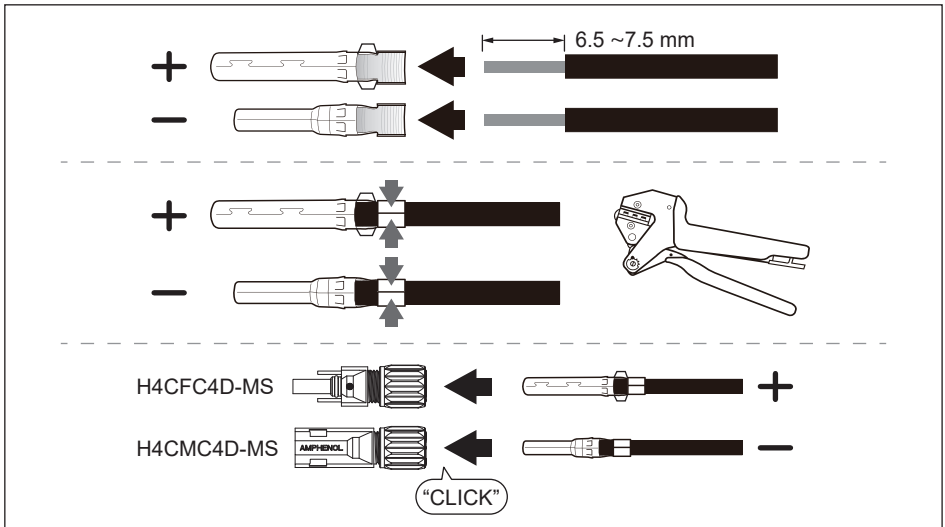

- 請勿拆除未使用的直流端防水塞，以避免水或異物侵入。

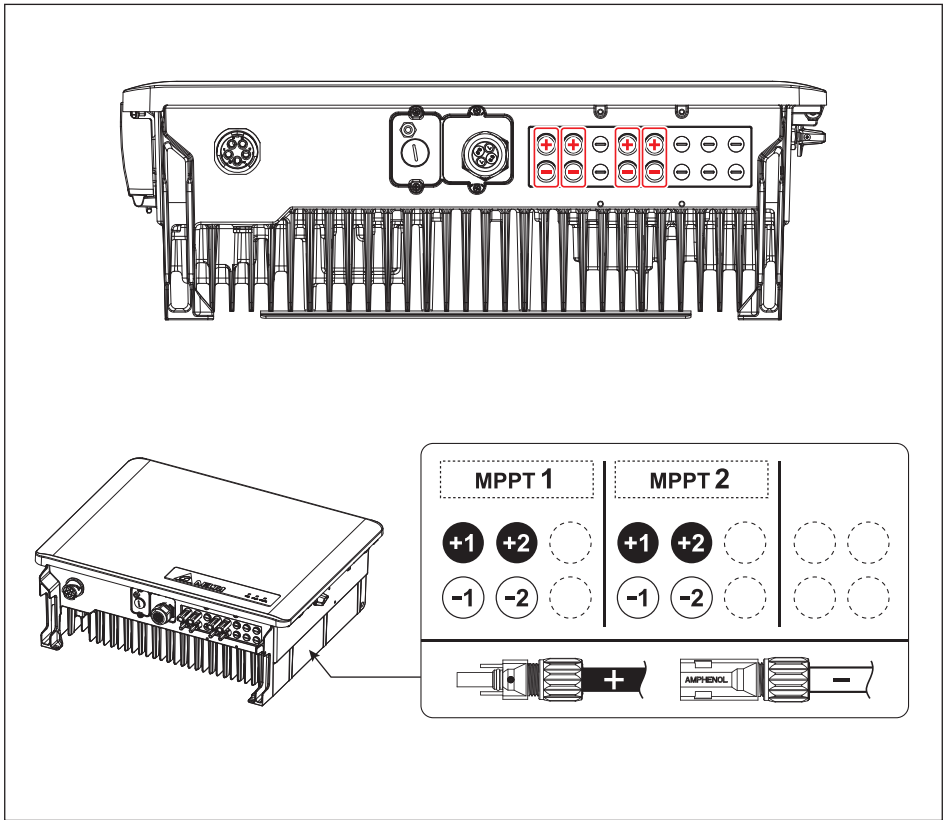
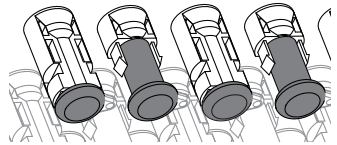

3.5 設備接地

將接地線壓接O型端子後，鎖附於機殼外部接地點。
機殼外部接地點位置如圖3-15所示。



圖 3-15 : 外部接地點

3.6 通訊模組配接方式

通訊模組如圖3-16所示。

該模組提供一組12V電壓源VCC、RS-485、乾接點、EPO和數位輸入端子供功率控制使用，並可擴充使用於選配的SUB_1G功能。

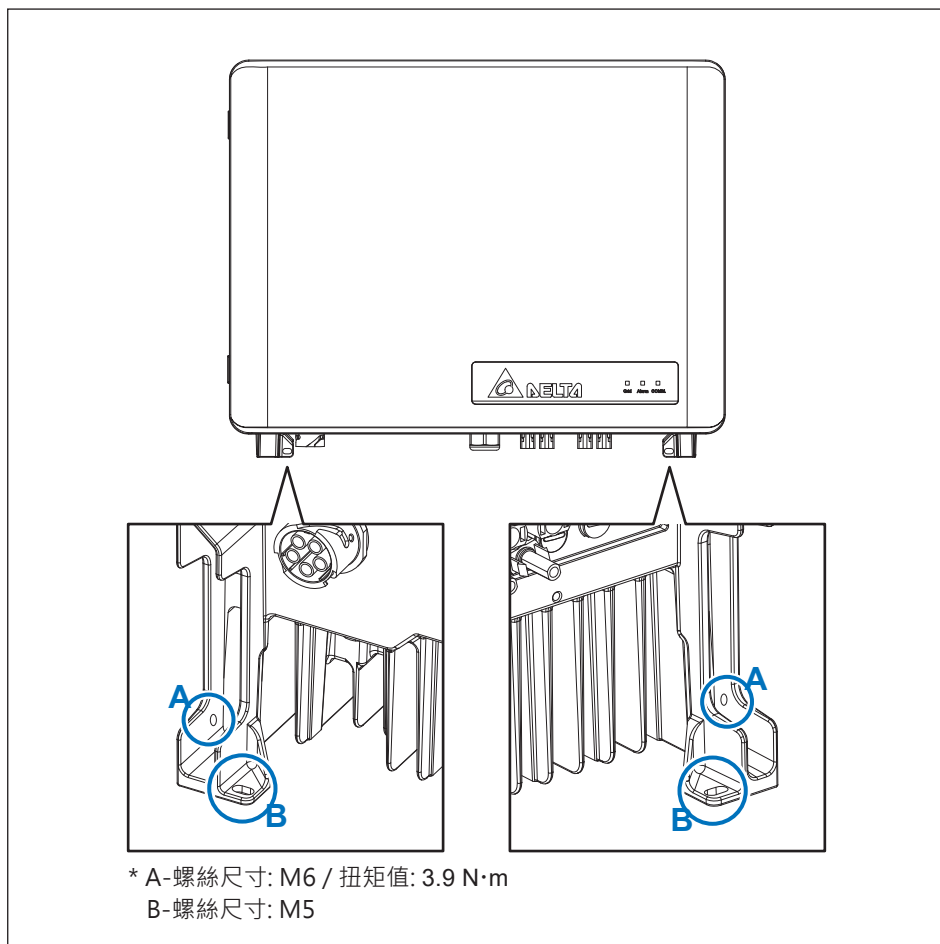

圖 3-16：通訊模組

3.6.1 連接通訊模組

變流器底部插槽中搭載通訊模組，模組托架以兩個防脫落螺絲固定於機箱上如圖 3-17所示。使用通訊模組時，請鬆開兩顆防脫落螺絲並取出拖架，拉出通訊模組後，將通訊線穿過防水導管，並按照以下各節所示進行電氣連接後，按上述步驟反序安裝模組，並確保組件與機箱正確組裝並妥善接合。

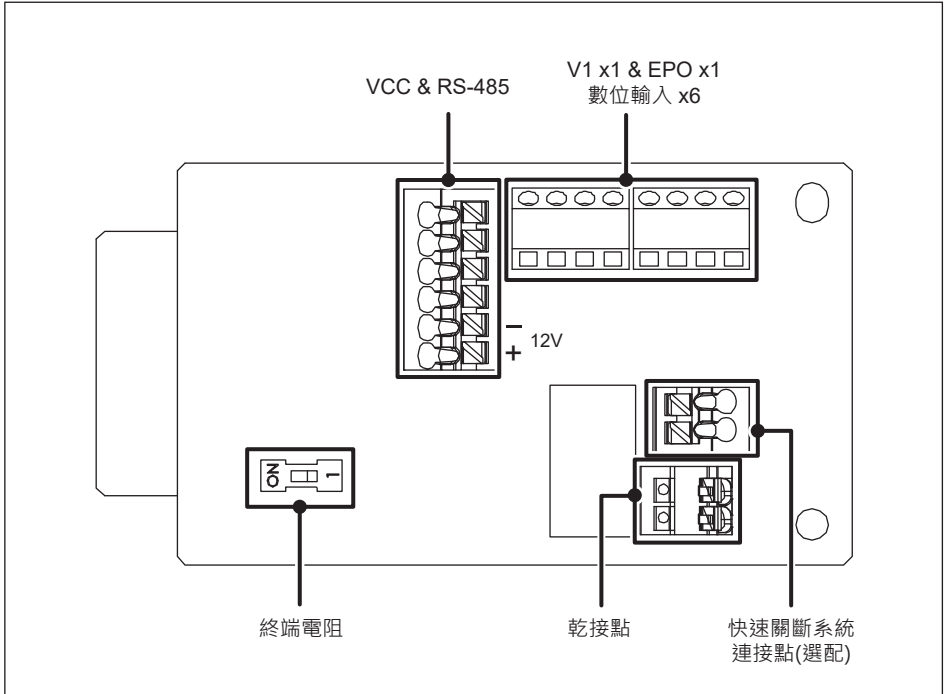

圖 3-17: 通訊模組位置與連接

注意



本機已通過標準檢驗局公告之「太陽光電變流器及監視單元資安檢測技術規範」，於變流器通訊模組安裝完畢後，請參照右方圖示，張貼全新專用資安封條(表2-1 項目9)於通訊模組托架外側，如未確實張貼而因此導致資安事件，則本公司概不負責。

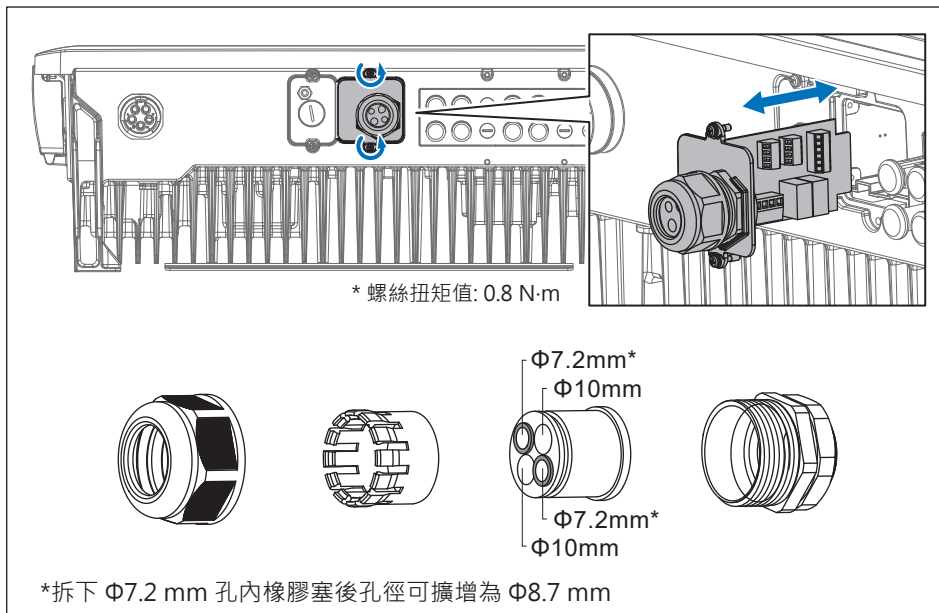
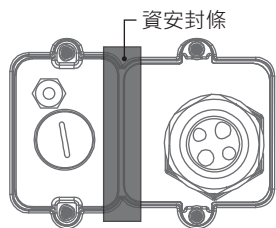

3.6.2 RS-485 連線

RS-485端子座腳位定義如表3-2所示

-腳位1與2提供直流電壓12V電源

(使用直流電壓12V電源時，請將開啟終端電阻開關至ON)

-腳位3與5 為RS-485差動信號之DATA+ 信號專用腳位

-腳位4與6 為RS-485差動信號之DATA- 信號專用腳位

依據上述的腳位，可以實現多台變流器的通信連接。

本機器設有120歐姆終端電阻，可使用通信模組上的控制開關進行切換，開關切換方式如表3-3所示。

不同的RS-485連接方式時，需使用不同的終端電阻設定方式。

- 當多台變流器連接時，只有最後一台變流器必須將終端電阻接通如圖3-18。
- 如果RS-485總線長度大於610m，建議使用Belden 3105A電纜或同規品來確保通信品質。

注意



- 為確保良好的通信品質，建議使用絞線之電纜方式配置。

表 3-2: RS-485 端子座說明

Pin	Function
1	VCC (+12V)
2	GND (非接地系統)
3	DATA+
4	DATA-
5	DATA+
6	DATA-

資訊



當RS-485需要接地時，請遵循以下步驟

1. 從隔離層剝出一條接地線(線徑: 0.5~1.5 mm²)，並做適當絕緣防護
2. 將接地線壓接Y端子(建議型號: SNYBL1-4)，並鎖附於下圖A處

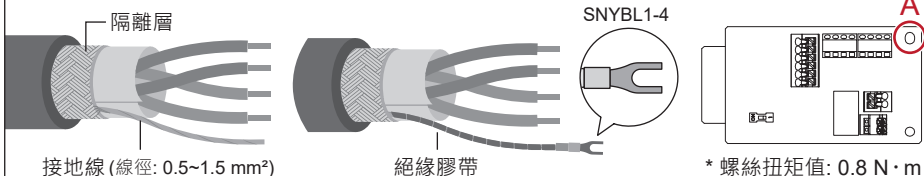



圖 3-18 : 多台併接通訊示意圖



表 3-3 : 終端電阻設定說明

	開關
ON	終端電阻 ON
1	終端電阻 OFF

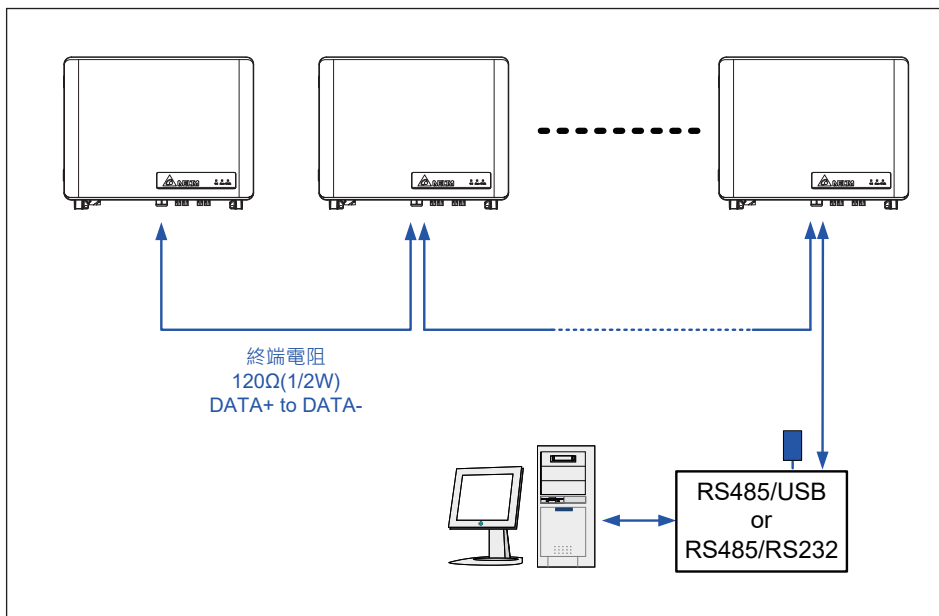
3.6.3 EPO 緊急關斷功能與數位輸入

本通信模組提供緊急關斷功能(EPO)與數位輸入。
可使用APP或Delta Solar System (DSS)進行設定。

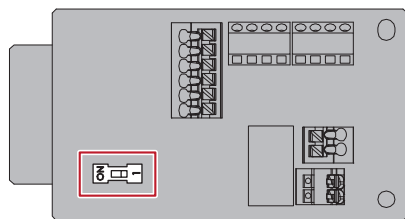

圖 3-19：緊急關斷功能與數位輸入端子座

利用V1和K0連接，可啟用EPO功能。此外，還可以利用數位輸入功能，進行功率降低控制，限制變頻器的有效輸出功率。此控制設置可依據表3-4所示的方式，將對應的兩個腳位進行短路來實現。

表 3-4: 數位輸入與EPO功能說明

短路腳位	變流器動作反應
V1 & K0	緊急關斷 (EPO)
V1 & K1	控制至0 % 額定功率
V1 & K2	控制至30 % 額定功率
V1 & K3	控制至60 % 額定功率
V1 & K4	控制至100 % 額定功率
V1 & K5	預留
V1 & K6	預留

3.6.4 乾接點連接說明

M15A_220 / M20A_220 提供一組乾接點端子，可依據變流器運行狀態控制外部裝置。該功能的接線端子如圖3-20所示，乾接點為常開狀態，其動作方式定義，使用者可藉由APP或DSS進行設定。



圖 3-20 : 乾接點連接位置圖

3.7 Wi-Fi

通訊模組支援變流器透過Wi-Fi功能(WPA2-PSK)與智慧型手機或平板電腦等裝置連接，使用者可藉由APP或DSS重新啟動Wi-Fi功能。

配件包中(物件8, 表2-1)附有Wi-Fi天線，請依循下述步驟安裝於機器底部

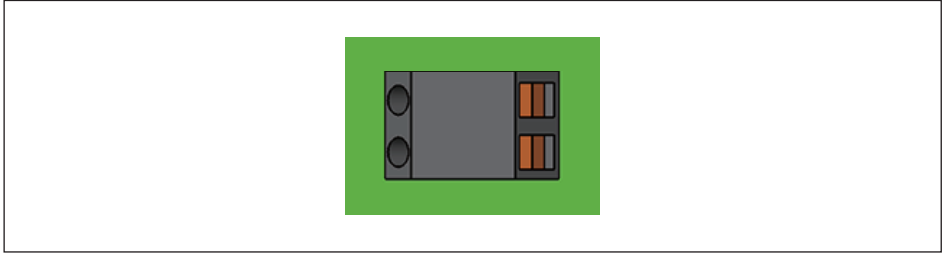
1. 卸除螺帽上的保護蓋
2. 將天線妥善鎖緊



圖 3-21 : Wi-Fi 天線安裝

注意

- 為確保良好的通訊品質，及避免設備損壞，請妥善安裝天線如下圖所示。

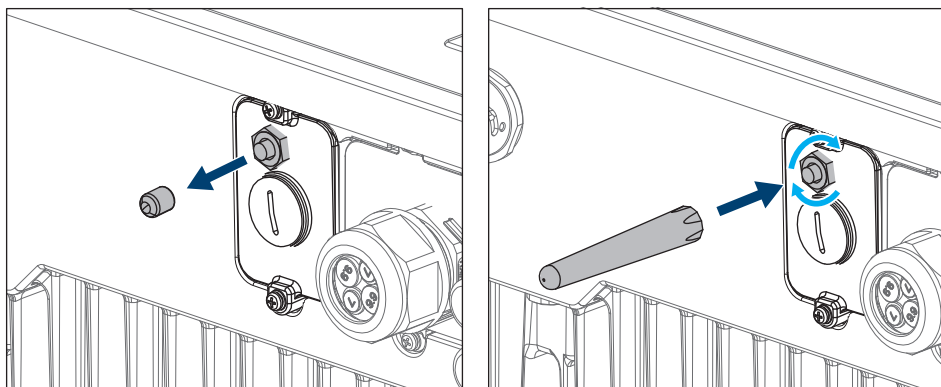
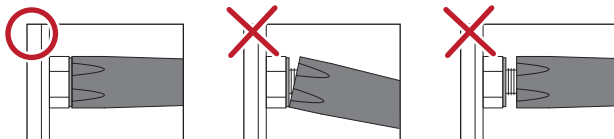

- 關於Wi-Fi及APP操作流程指南請參閱QR-code或下方連結內容。

<https://mydeltasolar.deltaww.com/index.php?p=manual>



- 進行Wi-Fi連接設定時，Wi-Fi裝置(Wi-Fi路由器，變流器，DC1...等)之間的通訊強度需大於-70dbm，若訊號強度<-70dbm會導致傳輸異常與資料遺失的風險，請嘗試調整相對位置來改善通訊品質。

4 試運行

注意：表面高溫，請勿觸碰！



- 當開蓋時請小心表面高溫。
- 表面冷卻前請勿接觸變流器。

4.1 LED燈號介紹

M15A_220 / M20A_220 提供3顆LED燈號顯示變流器狀態，如圖4-1所示。
LED燈與流器運行狀態對應資訊，請參考表4-1、4-2所示。



圖 4-1：顯示面板

表 4-1: LED 指示燈

狀況	Grid (綠)	Alarm (紅/黃)
Countdown	FLASH	OFF / OFF
On Grid	ON	OFF / OFF
Inverter Fault / Remote off	OFF	ON / OFF
Inverter Warning	ON (or OFF)	FLASH / OFF
Field Fault	OFF	OFF / ON
Field Warning	ON	OFF / FLASH
NO DC	OFF	OFF / FLASH SLOW
FW Upgrade	FLASH	FLASH / OFF
Standby	FLASH	OFF / FLASH
Check PV Power	FLASH FAST	OFF / FLASH FAST
System Lock	OFF	FLASH / FLASH

*FLASH: ON 1s / OFF 1s

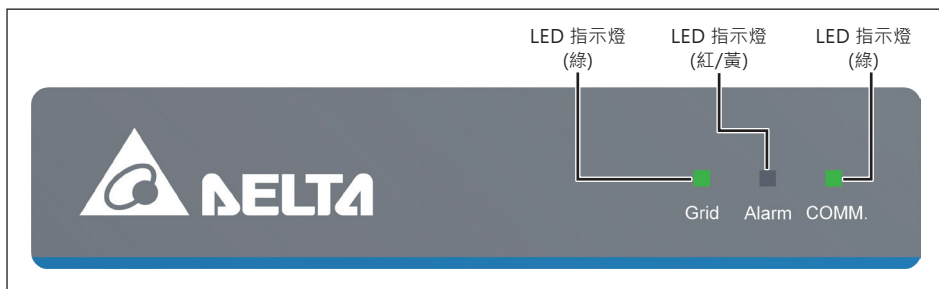
FLASH FAST: ON 0.25s / OFF 0.25s

FLASH SLOW: ON 5s / OFF 10s

表 4-2: 無線通訊指示燈

通訊狀態	COMM. (綠)
Offline	OFF
Wi-Fi	FLASH (ON 1s / OFF 2s)

4.2 自動ID設定

透過以下兩種軟體可以使用自動ID設定功能，一次設定所有變流器ID

- DSS (Delta Solar System)

變流器可透過RS485接線或是Wi-Fi連接至電腦，使用DSS進行設定。

- DeltaSolar APP

變流器透過Wi-Fi連接行動裝置(智慧型手機、平板等)，使用APP進行設定。

4.2.1 DSS連接

- ① 選取欲設定的機種
- ② 選擇電腦連接變流器途徑 (RS485接線 or Wi-Fi)
- ③ 若選擇RS485則需選取通訊端 (程式自動偵測)
- ④ 點擊 ▶





圖 4-2 : DSS連接

4.2.2 掃描變流器

- ① 點擊 “Auto ID ”
- ② 輸入變流器數量
- ③ 點擊 “Scan”

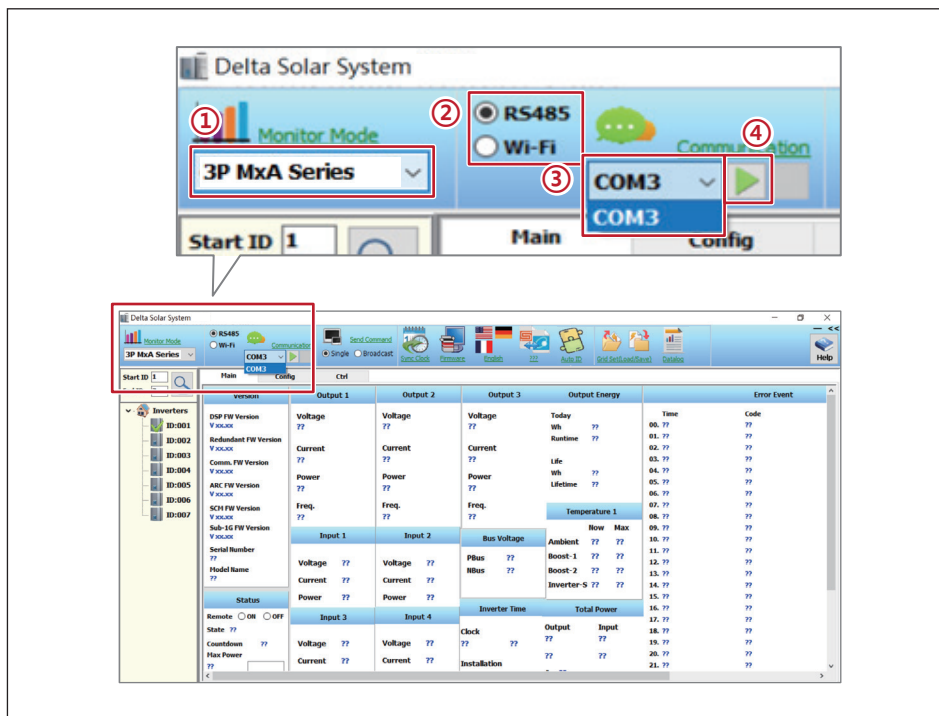

圖 4-3 : 變流器掃描

4.2.3 ID設定

- ① 被掃描到的裝置將顯示序號及系統預設ID，可以手動變更ID
- ② ID設定完成後點擊“Set ID”

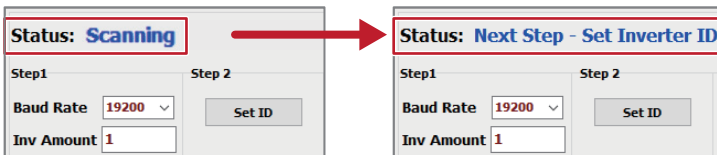
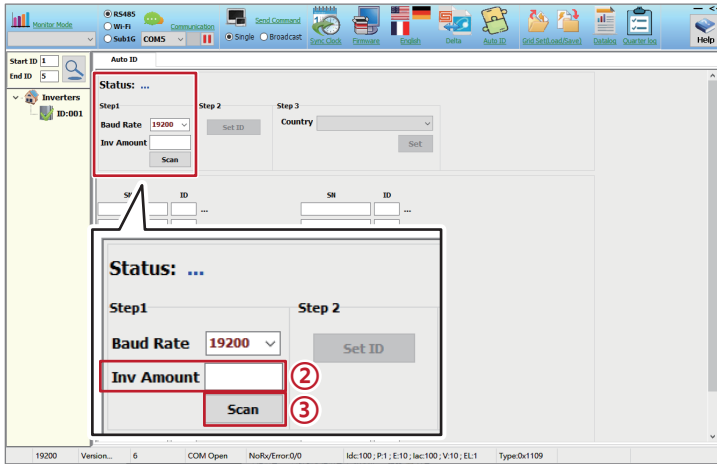

圖 4-4 : ID設定

4.2.4 國別設定

- ① 選取變流器國別
- ② 點擊 “Set”

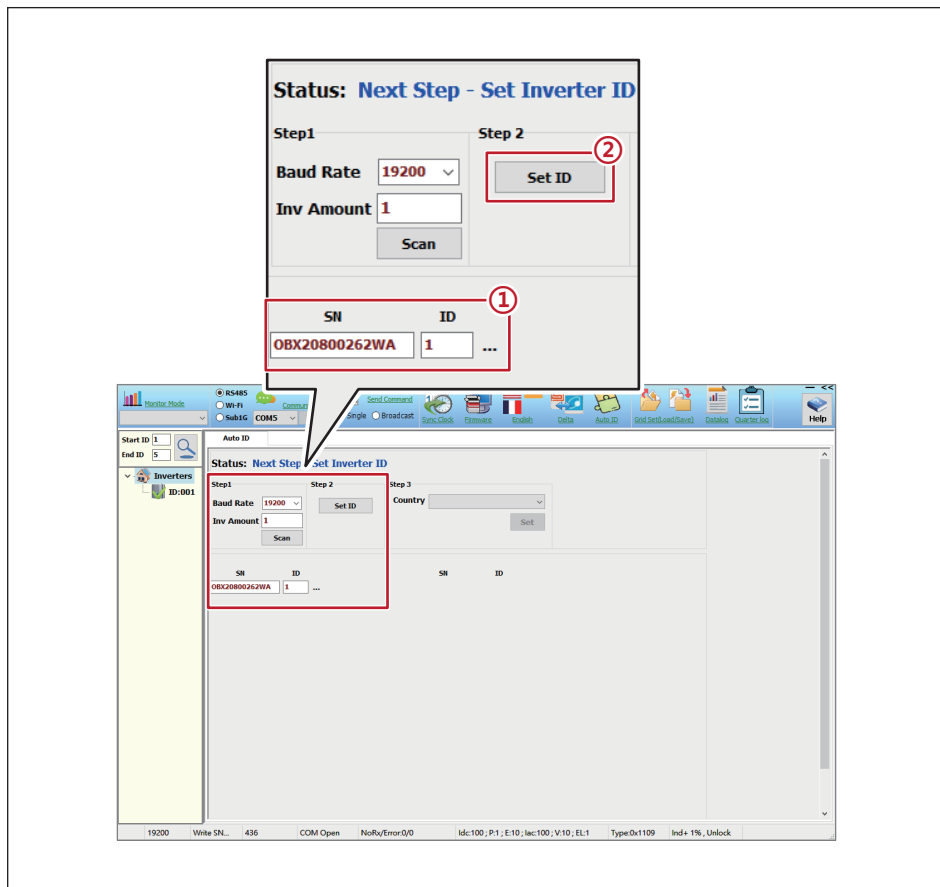

圖 4-5 : 國別設定

4.2.5 時間同步設定

點擊 “Sync Clock  ” 以同步時間設定

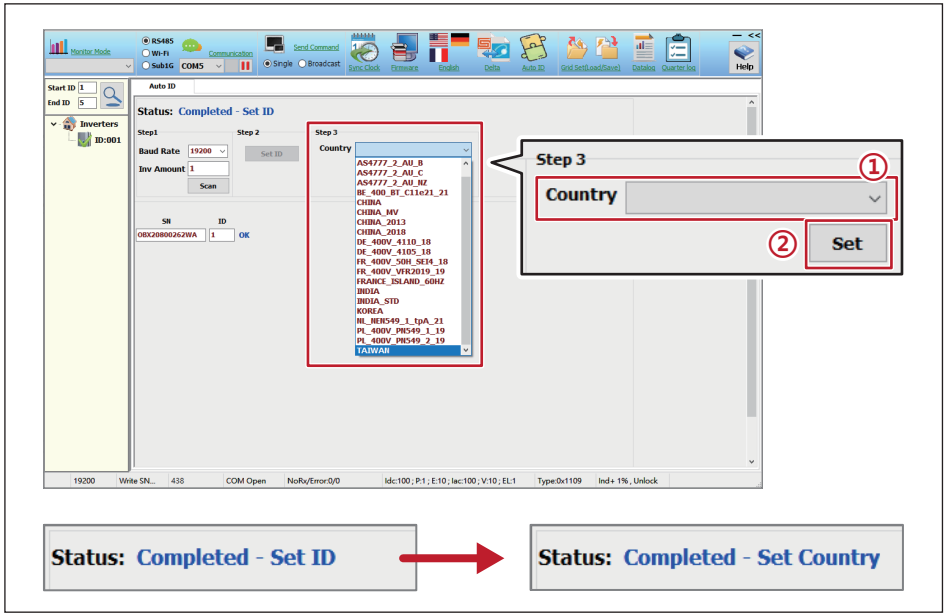

圖 4-6 : 時間同步設定

4.3 Delta功能設定

Delta 提供兩種機器設定方式：

DSS (Delta Solar System Software) 與 APP(DeltaSolar)

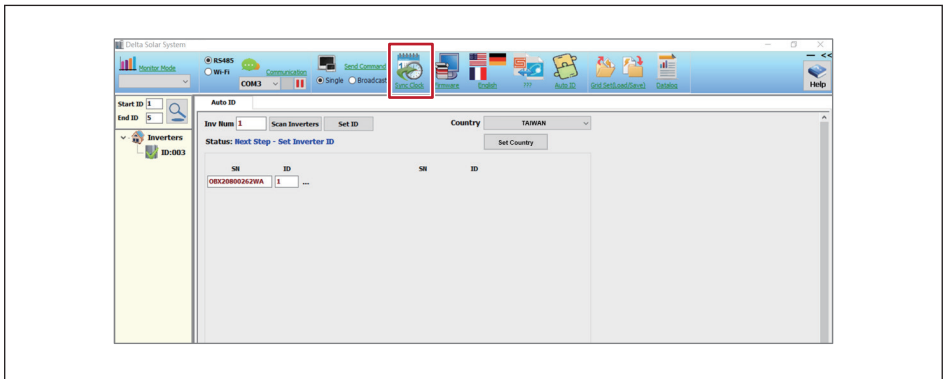
功能列表	
Active power control	Q(U) control (volt-var control)
P-F control (watt-frequecy control)	Q by night(Q setting 24/7)
P(U) control (volt-watt control)	Anti-PID
Fixed cos ϕ	Dry contact
Fixed Q(%)	ARC fault detection
Auto ID	Wi-fi

請掃描下方連結取得使用說明



DSS 操作手冊:

https://mydeltasolar.deltaww.com/manual/eng/SUB_1G/DSS.pdf



APP (DeltaSolar) 操作手冊:

<https://mydeltasolar.deltaww.com/index.php?p=manual>

5 維護

為確保變流器正常運轉並保持良好狀態，建議至少每半年進行一次維護，維護頻率應視環境、氣候條件與季節做適當調整。

危險：觸電!!



- 進行任何維護前，請確認交、直流電源皆關閉，且LED指示燈已熄滅，避免觸電危險。

5.1 開啟與關閉前蓋

為確保變流器正常運行，請依照下方步驟開啟或關閉前蓋。

5.1.1 開啟前蓋

警告!



- 在沒有任何雨遮的情況下，切勿在陰雨天氣時打開前蓋，以保護變流器。
- 當變流器外殼處於潮濕狀態，請擦拭過後再開啟前蓋，以防水氣進入箱體。

1. 使用鎖扣外蓋上的六角扳手，將鎖扣外蓋打開。(圖 5-1)
2. 鬆開鎖扣並開啟前蓋。(圖 5-1)
3. 使用六角扳手固定前蓋，避免因為強風導致前蓋搖晃。(圖 5-2)



圖 5-1：開啟與關閉前蓋



圖 5-2：使用六角板手將前蓋固定

5.1.2 關閉前蓋

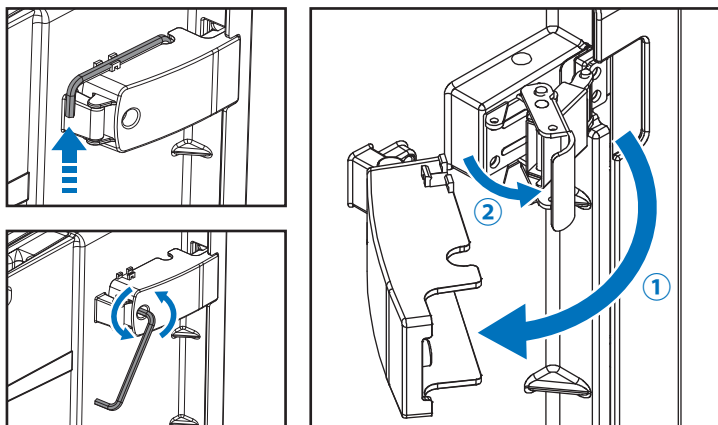
注意

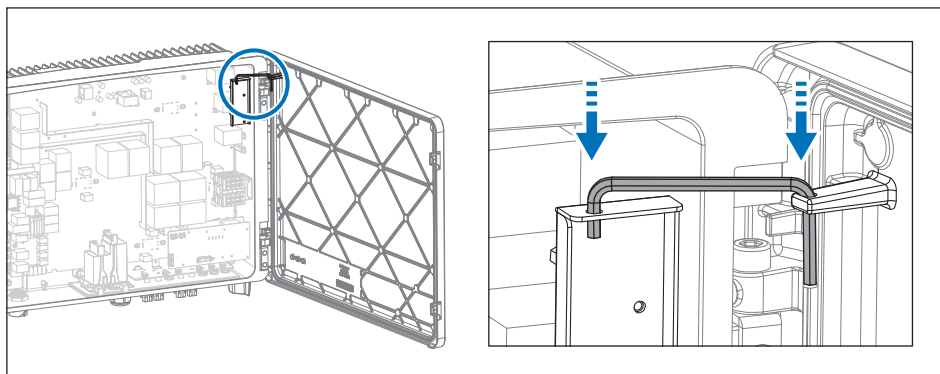

- 過多的水氣或灰塵進入可能會使零件損壞，導致降低變流器使用壽命，請確保變流器內部清潔。
- 配線或開蓋檢查作結束後，請將兩個鎖扣都確實扣上，避免機器失去IP66的防護。

1. 確認防水膠條及機殼接觸面保持清潔且狀況良好。
2. 確認內部的防護蓋皆已正確安裝。
3. 卸下固定前蓋的六角板手，並關閉前蓋。
4. 扣上鎖扣後，請參考下方注意警語，張貼全新一次性資安封條(表2-1 項目9)於上方鎖扣。
5. 蓋上鎖扣外蓋並使用六角板手擰緊。
6. 將六角板手固定於鎖扣外蓋上。

注意



- 本機已通過標準檢驗局公告之「太陽光電變流器及監視單元資安檢測技術規範」，請於配線或維護作業完畢並確實扣緊鎖扣後，張貼資安封條於鎖扣上，如未確實張貼而因此導致資安事件，則本公司概不負責。

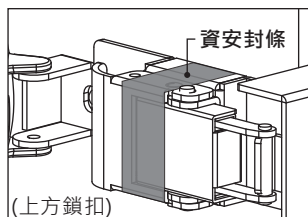

5.2 更換雷擊保護裝置 (SPD)

M15A_220 / M20A_220 在交流與直流端皆具有可更換的雷擊保護裝置。



圖 5-3 : 交流與直流側雷擊保護裝置位置



圖 5-4 : 交流與直流側的雷擊保護裝置

當APP或DSS出現故障訊息「W18- AC Surge」或「W17- DC Surge」時，請遵循以下步驟更換雷擊保護裝置。

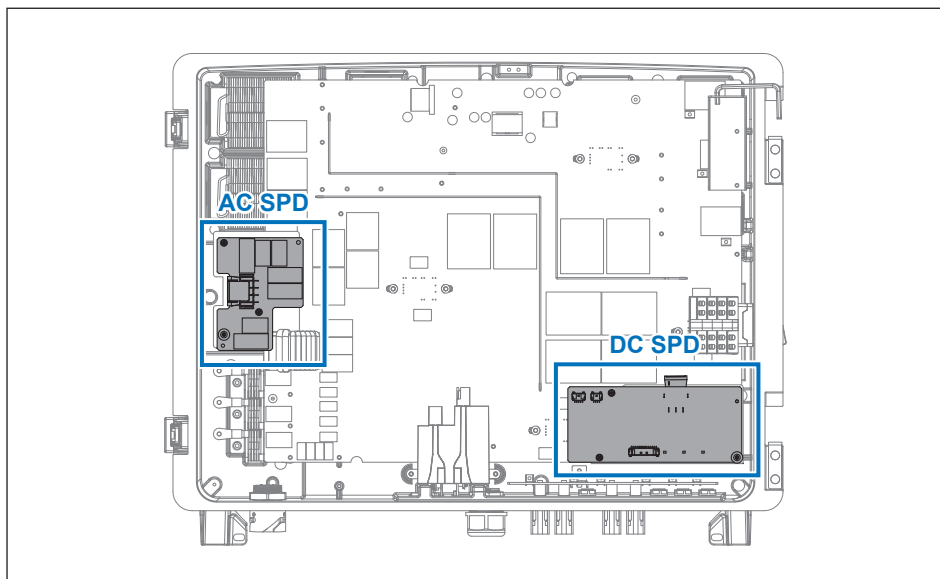
5.2.1 更換AC SPD模組

1. 將交流及直流電源關閉，並等待LED指示燈熄滅
2. 遵循5.1.1章節步驟開啟前蓋
3. 鬆開電路板上的3顆螺絲及兩條排線後，取下AC SPD模組
4. 將排線接至新的AC SPD模組，並以0.8 N·m的扭矩值將3顆螺絲鎖緊
5. 遵循5.1.2章節步驟關閉前蓋

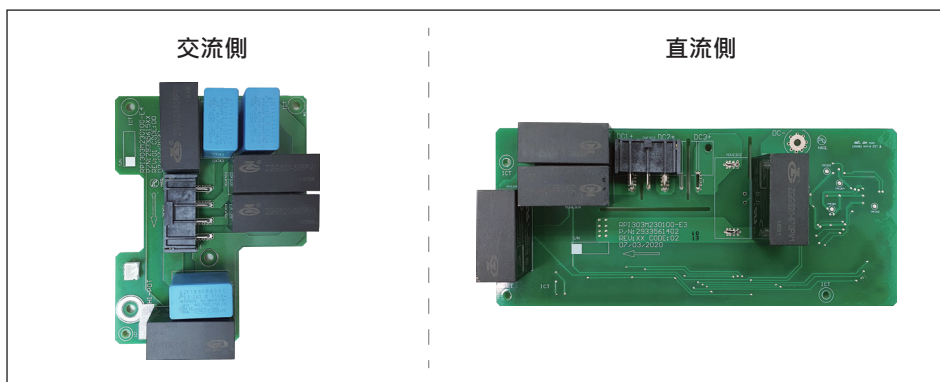

圖 5-5：AC SPD更換步驟



圖 5-6：移除AC SPD 螺絲與排線

5.2.2 更換DC SPD模組

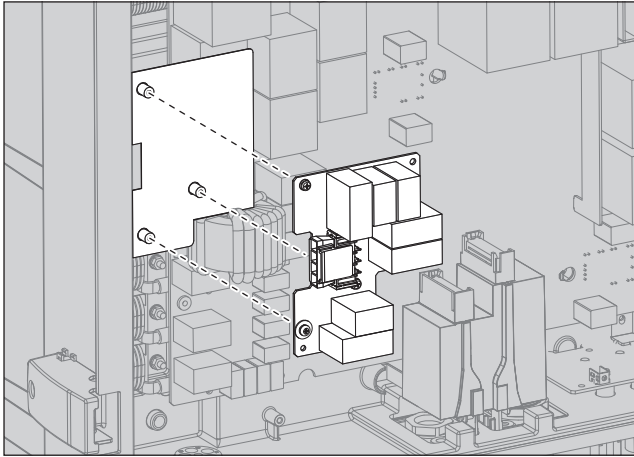
1. 將交流及直流電源關閉，並等待LED指示燈熄滅
2. 遵循5.1.1章節步驟開啟前蓋
3. 鬆開電路板上的3顆螺絲及兩條排線後，取下DC SPD模組
4. 將排線接至新的DC SPD模組，並以0.8 N·m的扭矩將3顆螺絲鎖緊
5. 遵循5.1.2章節步驟關閉前蓋

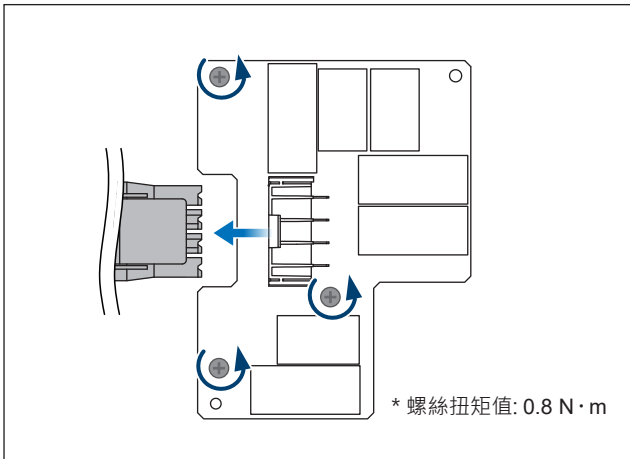

圖 5-7 : DC SPD更換步驟



圖 5-8 : 移除DC SPD 螺絲與排線

5.3 終止運轉

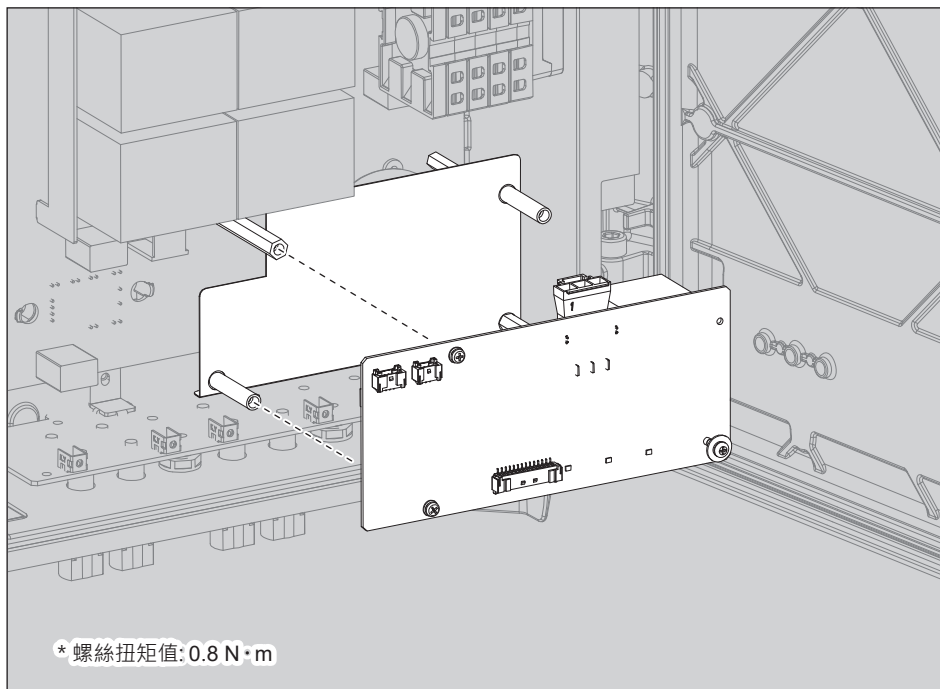
當變流器需要停止運轉進行維護或保存時，請依照下方指示拆除。

危險:觸電危險!!

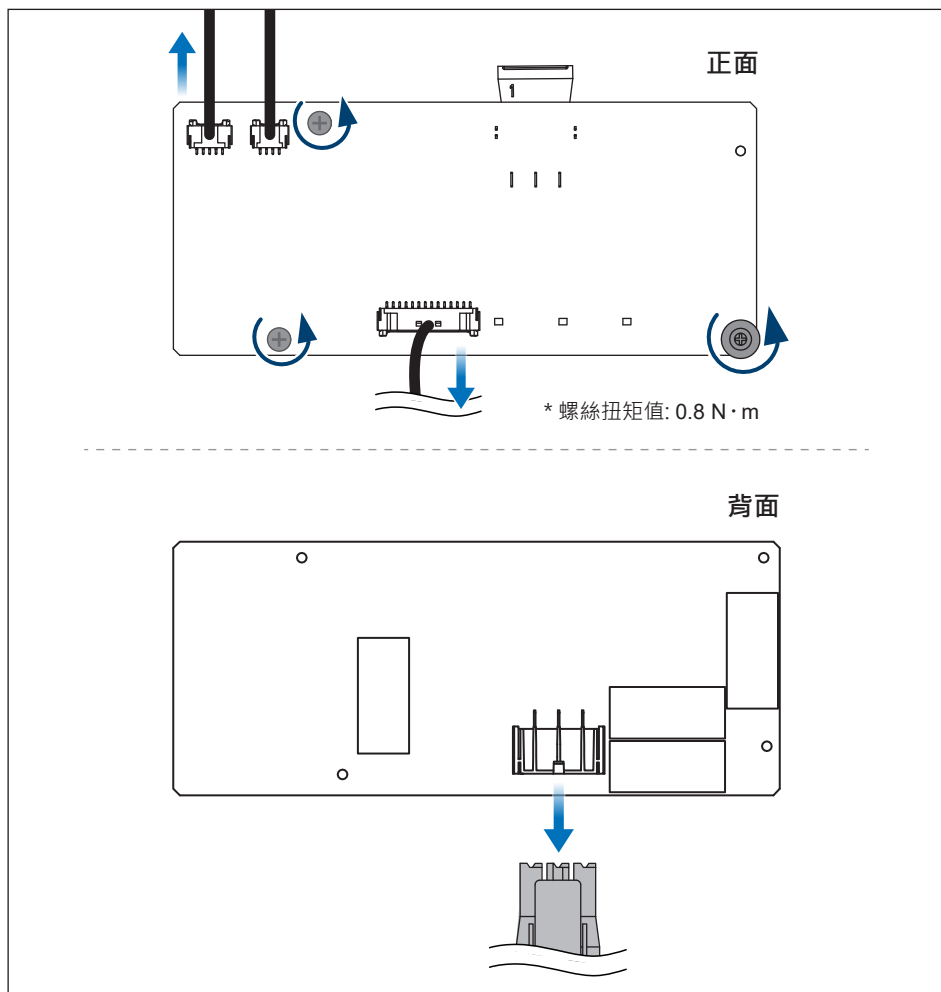

- 為避免嚴重傷亡，請依照下列步驟進行。

注意: 表面高溫 請勿觸碰！



- 變流器剛中斷時，請注意表面高溫。
- 直到表面降至適當溫度前，請勿碰觸變流器。

注意: 可能造成傷害！



- 變流器重達 40 公斤。
若拆卸及搬運過程不當或掉落，可能造成人員傷害。

- 關閉外部AC斷路器或開關，確認變流器與市電解離。
- 關閉變流器上的DC開關。
- 使用H4端子專用工具，將連接光伏模組的直流輸入H4端子皆移除。
- 卸下機器底部的Wi-Fi天線

■ RS-485 通訊模組

1. 卸下變流器中的通訊模組。
2. 移除端子座上的所有通訊線路。
3. 將解離後的通訊模組安裝回變流器中。

6 錯誤告警及排除問題

台達致力於打造高可靠標準的電子產品，若出現變流器無法正常動作的情況時，請使用故障排除指南(表6-1~6-4)中的說明，進行故障排除；若經過排除後仍無法解決問題，請聯繫客服中心尋求技術協助。

6.1 錯誤訊息(配置端故障)

表 6-1A: 錯誤訊息 (配置端故障)

資訊顯示	可能原因	故障排除
AC Freq High (E01)	市電頻率過高	1. 檢查變流器端的市電頻率 2. 檢查國家與電網設定
AC Freq Low (E02)	市電頻率過低	
Island (E03,E04,E05)	市電中斷	檢查AC 斷路器
AC phase jump (E06)	市電相位異常	當重複發生時，請聯繫客服人員，尋求技術支援
Grid Quality (E07)	在電網或靠近變流器附近非線性的負載	當重複發生時，請聯繫客服人員，尋求技術支援
AC phase abnormal (E08)	AC端連接錯誤	檢查AC連接，必須和使用手冊一致
No Grid (E09)	1. AC 斷路器跳開 2. AC 接頭未正確連接	1. 斷開AC 斷路器 2. 檢查連接AC接頭並確認其連接至變流器
AC Volt Low (E10)	1. 市電電壓過低 2. 電網設定錯誤 3. AC端連接錯誤	1. 檢查市電與變流器端的連接 2. 檢查國家或電網設定 3. 檢查AC接頭連接
AC Volt High (E11)	1. 市電電壓過高 2. 電網設定錯誤	
EPO (E25)	緊急關斷按鈕被啟動	請解除EPO按鈕
DC Volt High (E30)	輸入電壓超過 1000Vdc	修正solar array設定並使得Voc小於1000Vdc
Insulation Fault (E34)	太陽能模組與接地間發生隔離阻抗問題	1. 檢查太陽能模組接地是否確實 2. 檢查變流器接地是否確實 3. 檢查直流斷路器是否受潮
Remote OFF (E36)	外部通訊執行遠端關機	請檢查外部通訊Remote OFF設定

6.2 故障代碼(變流器故障)

表 6-2A: 錯誤訊息 (變流器故障)

資訊顯示	可能原因	故障排除
DC Injection (F01,F02,F03,F04)	市電波形異常	請聯繫客服人員，尋求技術支援
Temperature High (F05)	變流器內部環溫或功率模組溫度過高	檢查設備的周遭和環境
Amb Temp Fault (F06)	功率模組溫度偵測電路異常	請聯繫客服人員，尋求技術支援
Temperature Low (F07)	變流器內部環溫或功率模組溫度過低	檢查設備的周遭和環境
Boost Temp Fault (F08)	功率模組溫度偵測電路異常	請聯繫客服人員，尋求技術支援
Bidir. Temp Fault (F09)	功率模組溫度偵測電路異常	請聯繫客服人員，尋求技術支援
Inveter Temp Fault (F10)	功率模組溫度偵測電路異常	請聯繫客服人員，尋求技術支援
AC RLY Fault (F13)	1. 繼電器驅動電路異常 2. 繼電器異常	請聯繫客服人員，尋求技術支援
FW Unmatch (F14)	韌體不相容	請聯繫客服人員，尋求技術支援
AC Sensor Fault (F15)	輔助電源電路異常	1. 請確認直流端子極性(當同時出現W08時) 2. 請聯繫客服人員，尋求技術支援
Vdc Sensor Fault (F16)	輔助電源電路異常	請聯繫客服人員，尋求技術支援
Idc Sensor Fault (F17)	輔助電源電路異常	1. 請確認直流端子極性(當同時出現W08時) 2. 請聯繫客服人員，尋求技術支援
AC Sensor Fault (F18)	輔助電源電路異常	1. 請確認直流端子極性(當同時出現W08時) 2. 請聯繫客服人員，尋求技術支援
Idc Sensor Fault (F19)	輔助電源電路異常	請聯繫客服人員，尋求技術支援
Red COMM Fault (F22)	變流器內部通訊異常	請聯繫客服人員，尋求技術支援
DSP COMM Fault (F23)	變流器內部通訊斷線	請聯繫客服人員，尋求技術支援

表 6-2B: 錯誤訊息 (變流器故障)

資訊顯示	可能原因	故障排除
Ground Cur. High (F24)	太陽能模組與接地隔離阻抗異常	1. 檢查輸入端的絕緣 2. 請聯繫客服人員，尋求技術支援
Iac Unbalance (F26)	1. 變流器內部的電源線未連接 2. 電流回授電路無效	檢查AC接頭連接
RCMU Fault (F27)	RCMU連接中斷	請聯繫客服人員，尋求技術支援
AC RLY Short (F28)	AC 繼電器短路	請確認端子座配線與市電端配線是否正確
AC RLY Open (F29)	AC 繼電器開路	請聯繫客服人員，尋求技術支援
Bus Unbalance (F30)	變流器內部直流電壓不平衡	重新啟斷DC開關
Bus Voltage High (F31, F32, F33, F34, F35)	Bus 電容電壓過高	1. 請重新啟動DC開關 2. 修正太陽能板設定，並使得Voc 小於 1000Vdc (當同時出現E30時)
AC Current High (F36, F37, F38, F39, F40, F41)	操作期間突波發生	請聯繫客服人員，尋求技術支援
AC CT Fault (F42)	交流側R相電流感測器異常	請聯繫客服人員，尋求技術支援
AC CT Fault (F43)	交流側S相電流感測器異常	請聯繫客服人員，尋求技術支援
AC CT Fault (F44)	交流側T相電流感測器異常	請聯繫客服人員，尋求技術支援
AC Current High (F45)	交流電流輸出過大	重新啟斷DC開關
ZC Circuit Fault (F50)	相位偵測電路異常	請聯繫客服人員，尋求技術支援
Inv Circuit Fault (F51)	電壓轉換電路異常	請聯繫客服人員，尋求技術支援
Boost Circuit Fault (F52)	升壓電路異常	請聯繫客服人員，尋求技術支援
Arc Circuit Fault (F58)	1. 電弧偵測硬體異常 2. 電弧偵測測試異常	請檢查電弧偵測電路，確認接線正確
Arc Fault (F59)	變流器偵測到電弧異常	1. 請檢查直流側接線有無異常或毀損 2. 更換直流側接線並到DSS解除ARC鎖機狀態 3. 請聯繫客服人員，尋求技術支援

表 6-2C: 錯誤訊息 (變流器故障)

資訊顯示	可能原因	故障排除
DC Current High (F60,F61,F70,F71)	直流端過電流保護	重新啟斷DC開關
Ext COMM. Fault (F74)	外部通訊異常	1. 請檢查外部通訊接線是否異常 2. 請聯繫客服人員，尋求技術支援

6.3 警告代碼(配置端警告)

表 6-3A: 警告代碼 (配置端警告)

資訊顯示	可能原因	故障排除
De-rating (W07)	<ol style="list-style-type: none"> 1. 本體及環境溫度過高 2. 實功率限制功能作動 3. P-F功能作動 4. P(V) 功能作動 5. 市電電壓過低 6. 輸入電壓過低 7. 輸入電壓過高 8. 爬升功能 	<ol style="list-style-type: none"> 1. 確認安裝機器本體及環境溫度 2. 確認國別及最大功率限制參數設定 3. 確認市電頻率是否異常 4. 確認市電電壓是否異常 5-1. 確認市電電壓是否異常 5-2. 確認虛功控制功能設定 6. 確認PV panel輸入電壓是否過低 7. 確認PV panel輸入電壓是否過高 8. 確認爬升功能設定
String fault (W08)	<ol style="list-style-type: none"> 1. 直流端子極性錯誤 2. 太陽能組串不匹配 3. 組串電流偵測電路異常 	<ol style="list-style-type: none"> 1. 確認直流端子極性 2. 確認PV panel各組串的開路電壓是否異常 3. 請重開直流開關與交流斷路器 4. 請聯繫客服人員，尋求技術支援
String Current Low (W23)	DC端子連接異常	<ol style="list-style-type: none"> 1. 請檢查直流配線與保險絲 2. 請聯繫客服人員，尋求技術支援

6.4 警告代碼(變流器警告)

表 6-4A: 警告代碼 (變流器警告)

資訊顯示	可能原因	故障排除
Fan Fail (W11)	<ol style="list-style-type: none"> 1. 一個或多個風扇鎖死 2. 一個或多個風扇無效 3. 一個或多個風扇未連接 	請聯繫客服人員，尋求技術支援
DC SPD Fault (W17) AC SPD Fault (W18)	一個或多個DC/AC SPD無效	<ol style="list-style-type: none"> 1. 檢查DC/AC SPD的連接線 2. 更換DC/AC SPD板
Boost Circuit Fault (W30)	升壓電路故障	請聯繫客服人員，尋求技術支援

7 技術資料

表 7-1A: 規格		
Model	M15A_220	M20A_220
直流輸入		
最大輸入電壓	1100 V *1	
工作電壓範圍	200 - 1000 V	
MPP 電壓範圍 @ AC400V	380 - 900 V	480 - 900 V
啟動電壓	> 250 V	
輸入電壓	600 V	
最大輸入電流	25 A / MPPT, Total: 45 A	26 A / MPPT, Total: 48 A
最大輸入功率	9.85 kW /MPPT	13.5 kW /MPPT
允許最大短路電流	50 A per MPPT	
MPP 追蹤	2	
接頭種類	4 strings (2 pairs/MPPT), Amphenol H4 Connector	
直流開關	內建	
電流監控	內建	
電弧偵測功能	內建	
雷擊保護	Type II SPD	
交流輸出		
最大輸出功率	16.5 kVA	22 kVA
輸出功率	15kW@40°C ; 16.5kW@35°C	20kW@40°C ; 22kW@35°C
最大輸出電流	25 A	32 A
輸出電壓	220 / 380V, 230 / 400V (3Ø3W or 3Ø4W)	
工作電壓範圍	80% to 130% of Nominal AC Voltage	
工作頻率範圍	50 / 60Hz ± 5Hz	
功率因數(可調)	0.8 ind - 0.8 cap	
雷擊保護	Type II SPD	
T.H.D	< 3%	
夜間耗電 *2	< 2 W	
浪湧電流	110 A / 50 µs	
最大輸出故障電流 (rms)	40 A	
最大輸出過流保護 (peak)	77 A	

*1 本產品可承受最高電壓為1100 Vdc (超過1000 Vdc時變流器停止輸出)

*2 僅通訊待機狀態

表 7-1B: 規格		
Model	M15A_220	M20A_220
效率		
最高效率	98.4 %	98.5 %
歐洲效率	97.9 %	98.1 %
資訊		
通訊介面	RS-485 / Wi-Fi	
規範認證		
併網認證	IEC 62920 IEC 61439-2 IEC 62109-1/-2 CNS 15382 CNS 15426-1/-2	VDE-AR-N 4105 VDE-AR-N 4110 EN/IEC 61000-6-1/-2 EN/IEC 61000-6-3/-4 AS4777.2 : 2020
一般數據		
操作溫度範圍	-25 to +60°C (Derating Above 40°C)	
防水防塵等級	IP66	
操作海拔範圍	< 4000 m	
冷卻模式	自然風冷	
噪音	651 x 520 x 220 mm	
尺寸 (W x H x D)	31.6 dBA @1m, Amb25°C	
重量	40.5 kg	
相對濕度	0%-100% non-condensing	
污染等級	II	
過電壓類別	AC Output: III, DC Input: II	
反饋至太陽能板電流最大值	0	
電氣隔離	No	



圖 7-1: 效率曲線圖



圖 7-2: 環溫對應降額曲線圖(M15A_220)

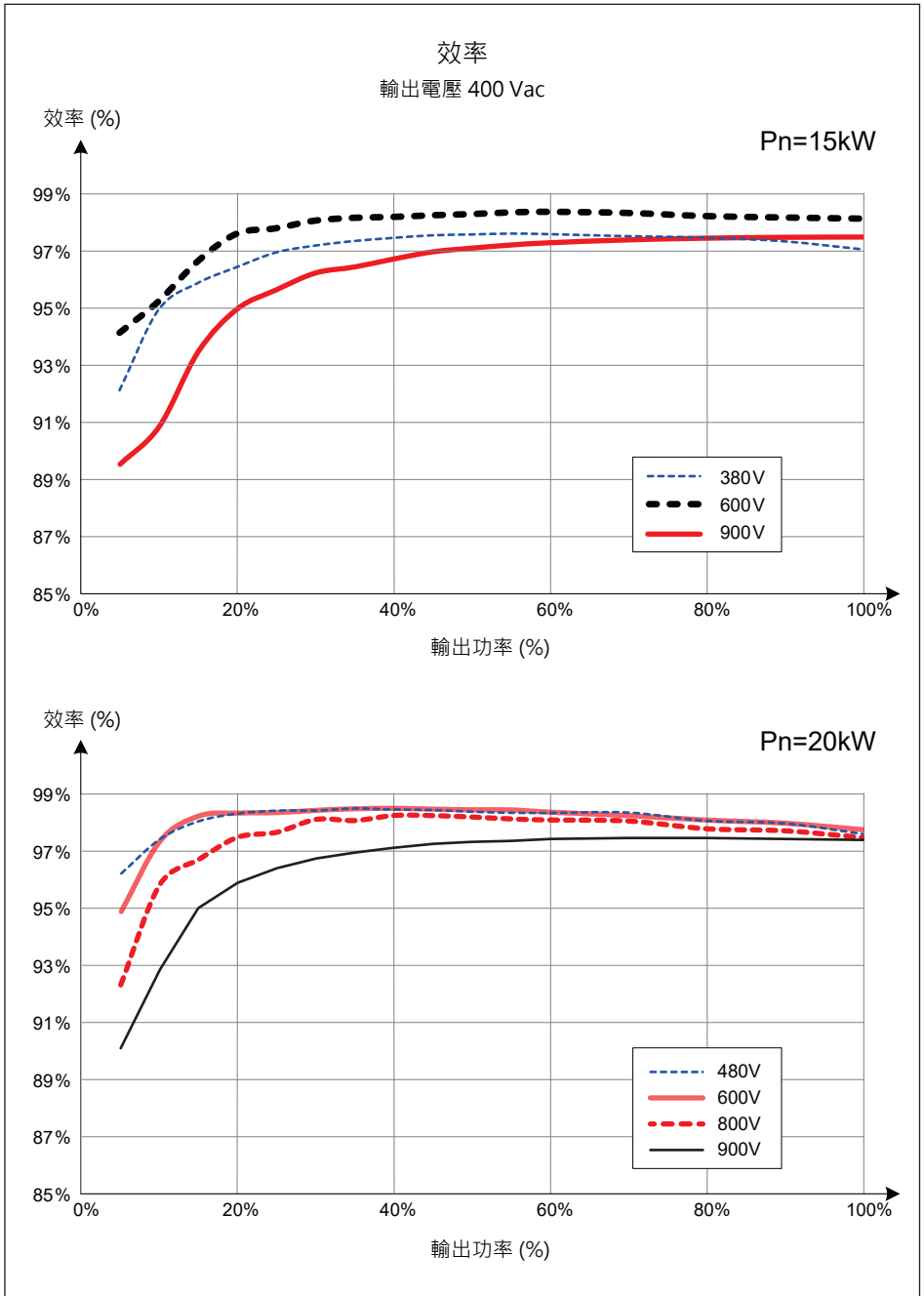

圖 7-3: 環溫對應降額曲線圖(M20A_220)

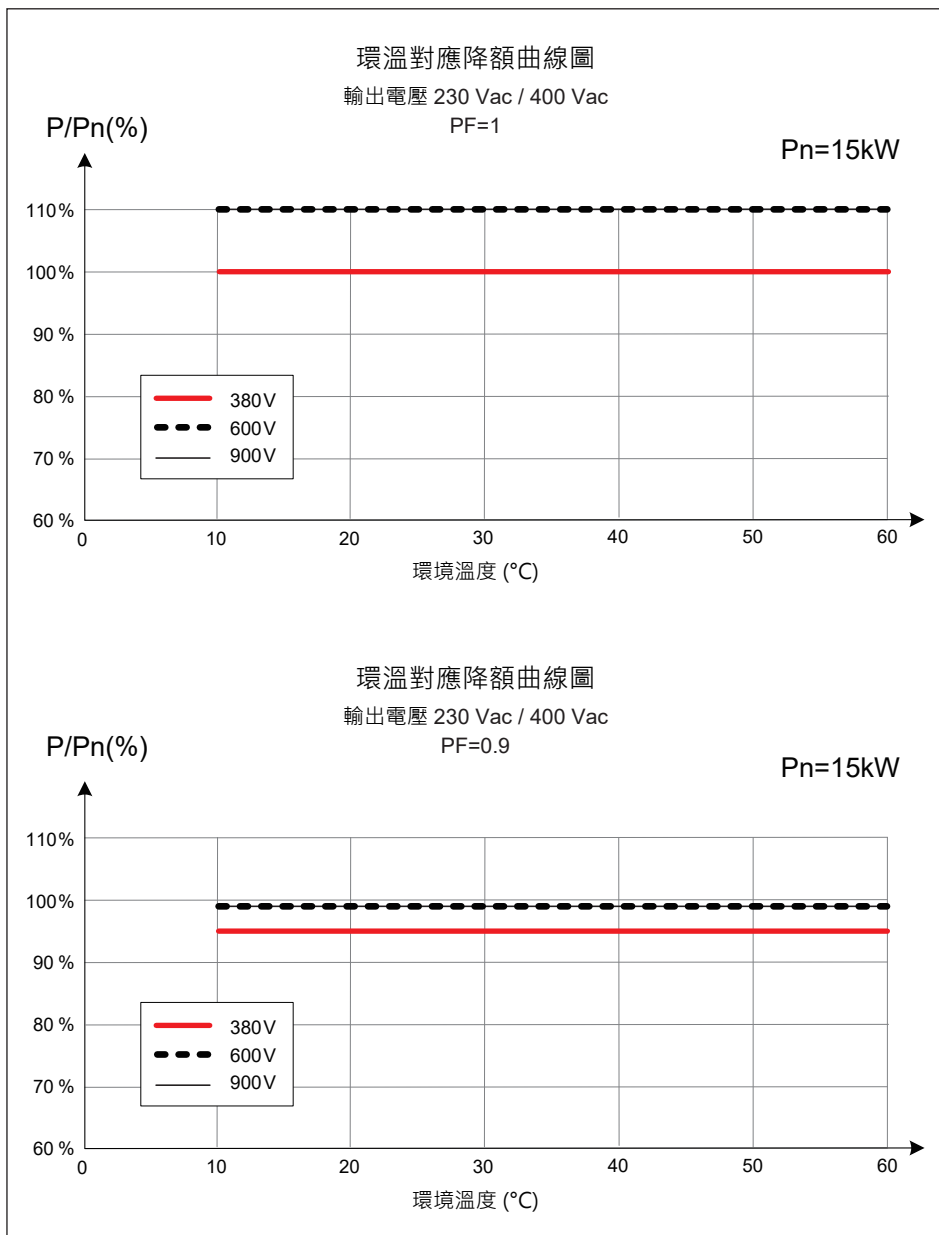

圖 7-4: 環境溫度對應輸出能力降額曲線

附錄: 組裝說明

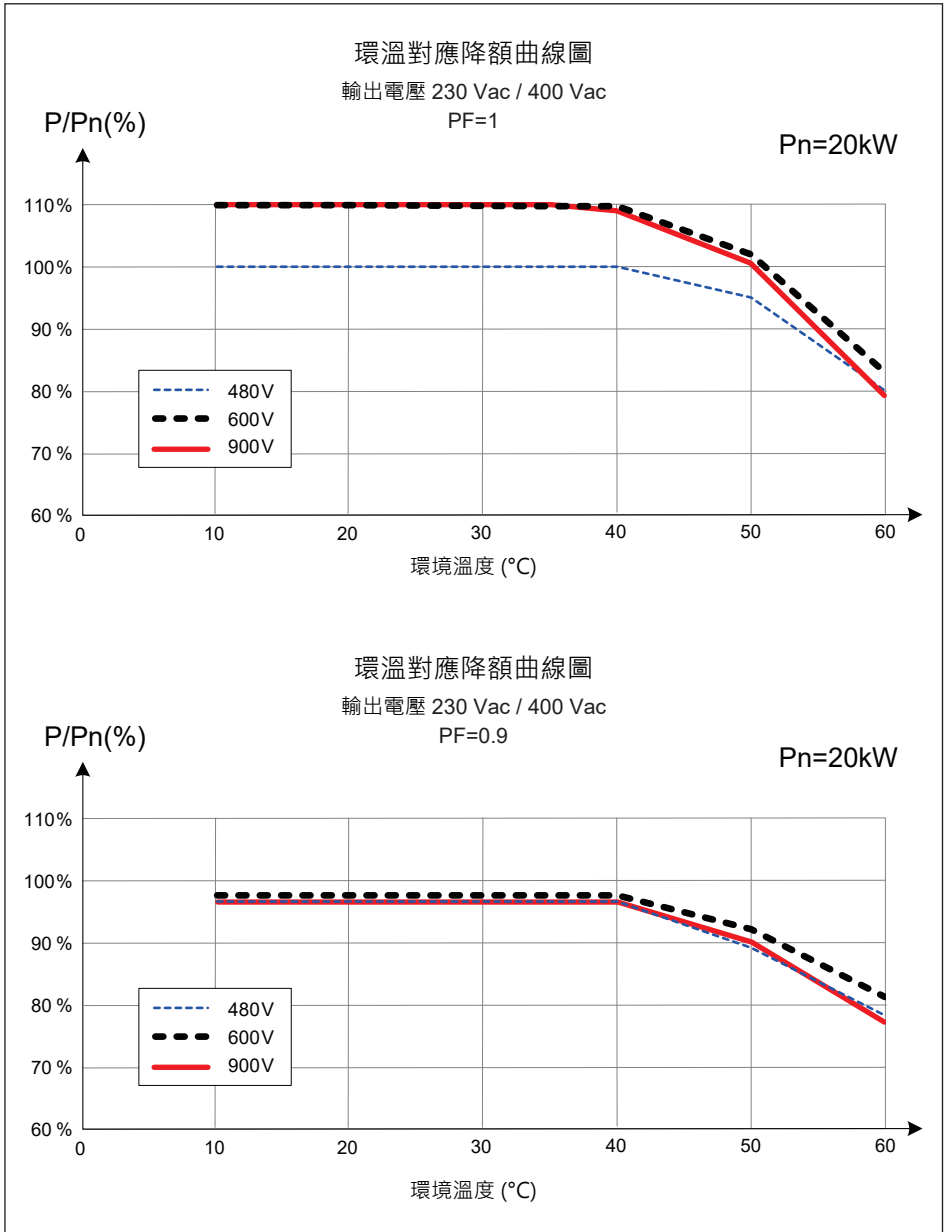

附錄-1: 組裝說明-1

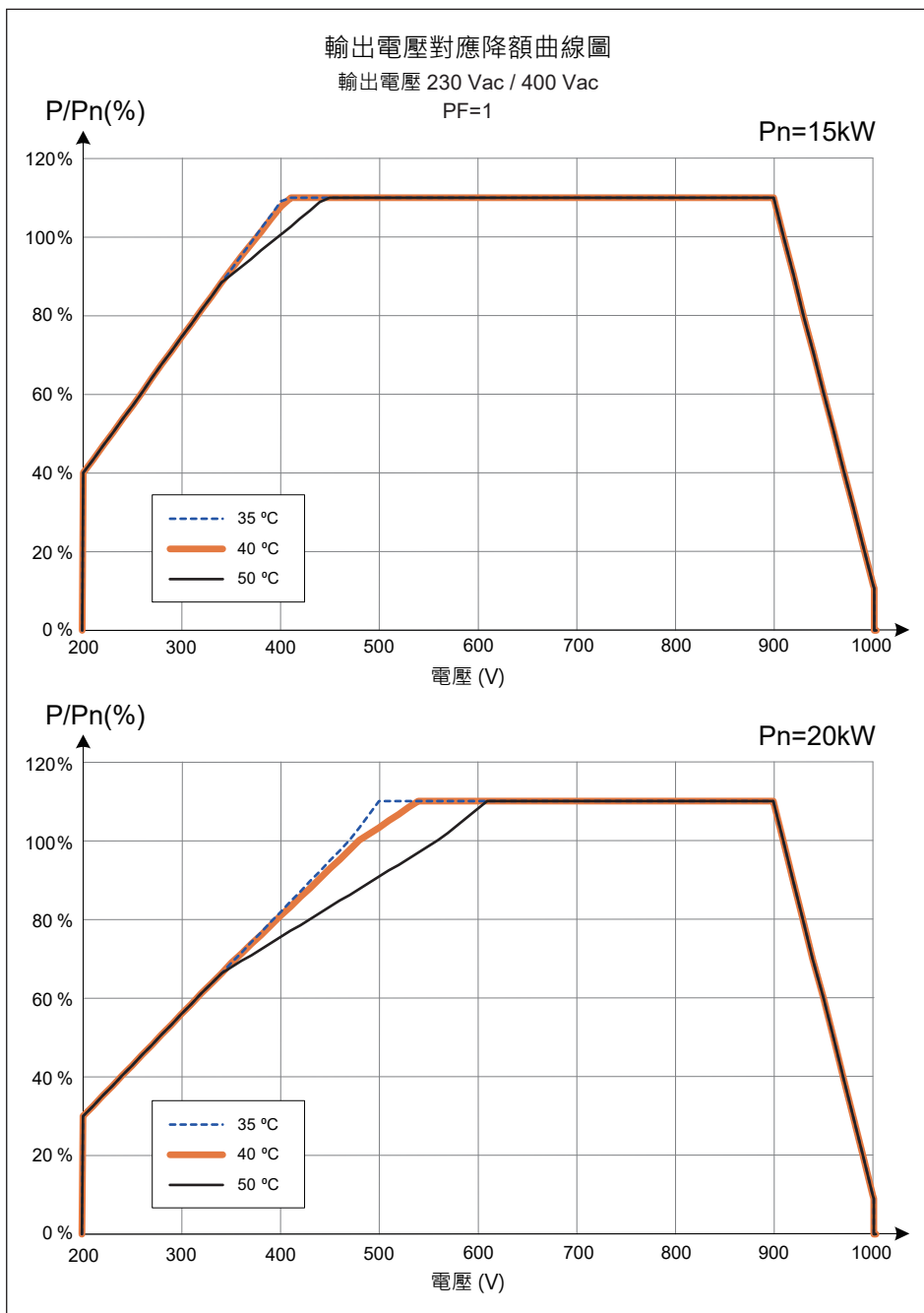
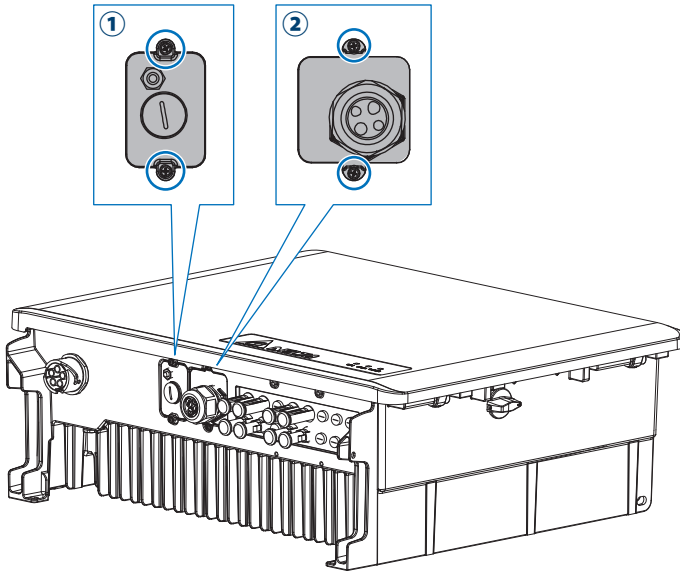
NO	位置	螺絲扭力
1	Wi-Fi 模組外蓋	8.0 kgf-cm (0.8N·m)
2	通訊外蓋	8.0 kgf-cm (0.8N·m)

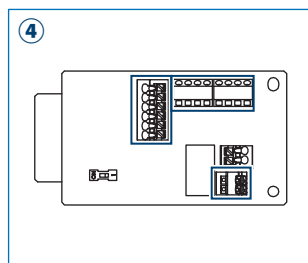
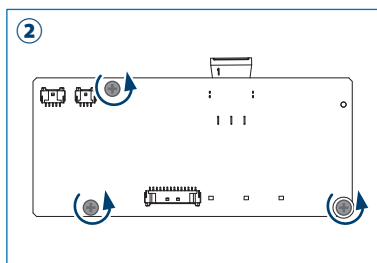
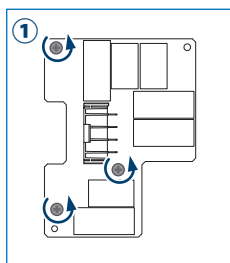
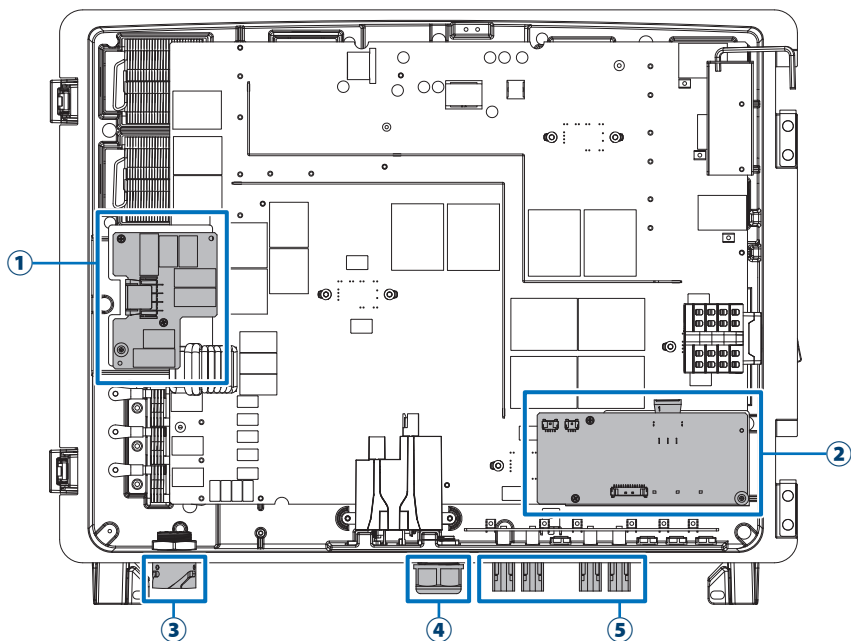

附錄-2: 組裝說明-2

NO	位置	螺絲扭力	導體橫截面
1	交流側雷擊保護裝置	8.0 kgf-cm (0.8N·m)	-
2	直流側雷擊保護裝置	8.0 kgf-cm (0.8N·m)	-
3	通訊模組	-	20 AWG (0.5mm ²)
4	AC 導線	7.1 kgf-cm (0.7N·m)	8 AWG (8 mm ²)~6 AWG (14 mm ²)
5	H4 導線	-	12/10 AWG (4/6mm ²)

